



Installation manual

iVector S2 Series (Hydronic Fan Convactor Unit With Intelligent Cooling and Heating Capabilities)

US

iVector S2 | 04/13/2023



PURMO
BY MYSON

Installation manual

iVector S2 – VS and VSI models

We want to thank you for choosing one of our products. We are confident that you will be happy with your selection because it represents the state of the art in the technology of climate control. By following the suggestions contained in this manual, the product you have purchased will operate without problems giving you optimum room temperatures with minimum energy costs.

The iVector S2 is available with casing (VS model) or without casing (VSI model), in 5 different lengths.

VS models can be mounted vertically on the wall or horizontally on the ceiling, with the option for integral controls (not ceiling), remote mounted controls or 0-10V option with BMS input or 0-10V remote control input. All units are available in 2 or 4 pipe options, and all units are supplied with pre-fitted valves.

VSI models can be mounted vertically (recessed wall mounting) or horizontally (recessed ceiling mounted), with the option for remote mounted control or 0-10V option with BMS input or 0-10V remote control input.

CONFORMITY

This unit complies with North America Standards:

- UL1995
- CSA C22.2 No. 236-15

SYMBOLS

The following symbols provide the necessary guidance for correct, safe use of this product.

Safety pictograms

These symbols may appear in the manual or on the product



WARNING / CAUTION

Signals that an appropriate safety instruction should be followed or caution to a potential hazard.



HOT SURFACE

Signals that the parts of the product could be hot and should not be touched without great care.



DANGEROUS VOLTAGES

Indicates hazards arising from dangerous voltages.



PROTECTIVE EARTH

Identifies any terminal intended for connection to an external conductor for protection against electric shock in case of a fault, or the terminal of a protective earth electrode.



HEAVY

Indicates that this product is heavy, and provision should be made for safe lifting and handling.



REFER TO MANUAL

Refer to relevant instructions within the product manual.

Contents

Safety and General Information	
1.1	Safety information 6
1.2	General information 7
1.3	Product range 7
1.4	Technical data 8
1.5	Dimensions 8-9
Installation	
2.1	Positioning the unit 10
2.2	Installation clearances 10
2.3	Side opening 11
2.4	Vertical floor or wall installation 11
2.5	Horizontal or ceiling installation (VS, VSI) 12
2.6	Mounting front grille safety support (VS) 12
2.7	Air intake grille fixing 13
2.8	Water connections 13
2.9	Condensate discharge 14
2.10	Filling and venting the system 15
2.11	Electrical connections 16
2.12	Maintenance 16
2.13	Cleaning the outer casing 16
2.14	Cleaning the air filter 16
Faults and Troubleshooting	
3.1	Troubleshooting 18
3.2	Fault-finding guide 18
Instructions 2-way valve	
4.1	Warnings 19
4.2	2-way valve parts list 19-21
4.3	Return valve pre-setting screw adjustment 22-23
4.4	Valve Insulation 24
Control Panel connection and setup	
5.1	Connection and setup of onboard control panel 25
5.2	Cooling mode additional functionality 25
5.3	Night time heating additional functionality 25
5.4	2 pipe & 4 pipe models with integrated control 26
5.5	2 pipe & 4 pipe models with remote-mounted control 27
5.6	Connection of multiple units using remote-mounted thermostat 28
5.7	LED Indications (A) 2 pipe & 4 pipe models with remote-mounted thermostat 28
5.8	Remote-control panel mounting 29
5.9	Wiring connection to remote-mounted control 30
5.10	Presence detection sensor input connection – units with remote-mounted control 30

Contents (continued)

Onboard and remote control setup menu	
6.1 Setup menu	31-32
0-10V Models	
7.1 0-10V fan control	33
7.2 Connection diagram with 0-10V DC thermostats / signals	33
7.3 Fan speed regulation	33
User instructions	
8.1 Onboard and remote-mounted control operation	34
8.2 Display	34
8.3 Key function	34
8.4 Activation	35
8.5 Heating / cooling operation modes setting	35
8.6 Stand-by	35
8.7 Temperature selection	35
8.8 Automactic operation	36
8.9 Silent operation	36
8.10 Night-time operation	36
8.11 Operation at maximum fan speed	36
8.12 Key lock	36
8.13 Reduce brightness to minimum	36
8.14 Room temperature probe regulation offset	37
8.15 Switching off for longer periods	37

Safety and general information

1.1 Safety information

-  This appliance **MUST NOT** be installed in a bathroom or other similar high humidity areas.
-  This appliance **MUST** be earthed.
-  This appliance must be installed by a qualified installer.
-  The electrical installation must comply with local or national wiring regulations and should be carried out by a qualified electrician.
-  This appliance can be used by children aged from 8 years and above and persons with reduced physical, sensory or mental capabilities or lack of experience and knowledge if they have been given supervision or instruction concerning use of the appliance in a safe way and understand the hazards involved. Children shall not play with the appliance. Cleaning and user maintenance shall not be made by children without supervision.
-  For the correct installation of this product, it is essential that fixing is carried out in such a way that it is suitable for intended use and predictable misuse. A number of elements need to be taken into consideration including the fixing method used to secure it to the surface, the type and condition of the surface itself, and any additional potential forces or weights that may happen to be applied to the unit, prior to finalising installation.
-  This product must not be installed immediately below a socket outlet.
-  This product must not be installed in areas where excessive dust exists.
-  This product can be hot when in use, and as such, presents a risk of burns to users on prolonged contact. The temperature of the product is dependent on system water temperature, as set by the installer or end user. Installers and users should ensure that those who may come into close proximity to the product are aware of the risk of burns.
-  The imbedded iVector S2 VSI series do not have a grille or covering plate. The installer must provide safety guards and air inlet/outlet grills to prevent accidental contact with the device.
-  **DO NOT** cover or obstruct the air inlet or outlet grilles.
-  Isolate electrical supply before carrying out any cleaning or maintenance activities.
-  This instruction leaflet is an integral part of the appliance. The installer **MUST** ensure it is left with the end user.
-  All repair and maintenance activities must be performed by suitably qualified personnel.

1.2 General information

Before proceeding with the installation, unpack the product and make sure that all the components are present, and that there is no concealed shipping damage.

Components include:

- unit
- instruction manual
- template
- accessories/mounting kit

This appliance has been designed both for heating and / or cooling applications and must be installed for this use only. The installation must take into consideration stated performance characteristics.

Check the location where the product is to be installed, the surface must be flat and the specified product clearances available. If fitted to a wood framed construction, there may be an adverse effect on sound levels especially at higher fan speeds. If the product is to be used for cooling applications, the disposal of condensate must be considered.

 If the appliance is not used for a long period of time, it is recommended that the product is electrically isolated, and the connecting valves are closed. Frost prevention measures must be taken including use of anti-freeze if appropriate.

 Avoid prolonged physical contact with the direct air flow.

Do not leave the room closed for long periods. Periodically open the windows to ensure fresh air exchange.

In the event of a water leak, isolate the electrical supply and close connecting valves. Contact the installer.

The manufacturer accepts no responsibility, either contractual or for consequential loss, for any damage caused to persons, animals or property as a result of incorrect installation, alteration, maintenance or improper use.

To ensure that the installation is carried out correctly and that the unit will perform as designed, carefully follow the instructions in this manual. Failure to follow the instructions can not only cause malfunctions of the appliance but will also invalidate the warranty and hence PG shall not respond for any damage to persons, animals or property.

All IP units contained in this document are converted from SI equivalent – all IP units nominal.

1.3 Product range

The iVector S2 is available with casing (VS model) or without casing (VSI model), in 5 different lengths.

VS models can be mounted vertically on the wall or horizontally on the ceiling, with the option for integral controls (not ceiling), remote mounted controls or 0-10V option with BMS input or 0-10V remote control input.

All units are available in 2 or 4 pipe options, and all units

are supplied with pre-fitted valves.

VSI models can be mounted vertically (recessed wall mounting) or horizontally (recessed ceiling mounted), with the option for remote mounted control or 0-10V option with BMS input or 0-10V remote control input.

1.4 Technical data

2 PIPES						
Technical Data (DC)	Model VS	VS 7-2P	VS 9-2P	VS 11-2P	VS 13-2P	VS 15-2P
	Model VSI	VSI 7-2P	VSI 9-2P	VSI 11-2P	VSI 13-2P	VSI 15-2P
Length VS	mm (inch)	735 (29)	935 (37)	1135 (45)	1335 (53)	1535 (61)
Length VSI	mm (inch)	378 (15)	578 (23)	778 (31)	978 (39)	1178 (46)
Heat exchanger water content VS/VSI	L (US Gal)	0.47 (0.12)	0.8 (0.21)	1.13 (0.30)	1.46 (0.39)	1.8 (0.48)
Maximum working pressure	bar (psi)	10 (145)	10 (145)	10 (145)	10 (145)	10 (145)
Maximum inlet water temperature	°C (°F)	82 (180)	82 (180)	82 (180)	82 (180)	82 (180)
Minimum inlet water temperature	°C (°F)	4 (39)	4 (39)	4 (39)	4 (39)	4 (39)
Water connections		Eurocone 3/4"	Eurocone 3/4"	Eurocone 3/4"	Eurocone 3/4"	Eurocone 3/4"
Power supply	V/ph/Hz	115/1/60	115/1/60	115/1/60	115/1/60	115/1/60
Maximum current	A	0.22	0.32	0.36	0.52	0.56
Maximum power	W	11	19	20	29	33
Weight VS	kg (lbs)	17 (38)	20 (44)	23 (51)	26 (58)	29 (64)
Weight VSI	kg (lbs)	9 (20)	12 (27)	15 (33)	18 (40)	21 (47)

IP units are converted from SI equivalent – all IP units nominal

4 PIPES						
Technical Data (DC)	Model VS	VS 7-4P	VS 9-4P	VS 11-4P	VS 13-4P	VS 15-4P
	Model VSI	VSI 7-4P	VSI 9-4P	VSI 11-4P	VSI 13-4P	VSI 15-4P
Length VS	mm (inch)	735 (29)	935 (37)	1135 (45)	1335 (53)	1535 (61)
Length VSI	mm (inch)	378 (15)	578 (23)	778 (31)	978 (39)	1178 (47)
Cooling coil water content	L (US Gal)	0.47 (0.12)	0.8 (0.21)	1.13 (0.30)	1.46 (0.39)	1.8 (0.48)
Heating coil water content	L (US Gal)	0.16 (0.04)	0.27 (0.07)	0.38 (0.10)	0.49 (0.13)	0.6 (0.16)
Maximum working pressure	bar (psi)	10 (145)	10 (145)	10 (145)	10 (145)	10 (145)
Maximum inlet water temperature	°C (°F)	82 (180)	82 (180)	82 (180)	82 (180)	82 (180)
Minimum inlet water temperature	°C (°F)	4 (39)	4 (39)	4 (39)	4 (39)	4 (39)
Water connections		Eurocone 3/4"	Eurocone 3/4"	Eurocone 3/4"	Eurocone 3/4"	Eurocone 3/4"
Power supply	V/ph/Hz	120/1/60	120/1/60	120/1/60	120/1/60	120/1/60
Maximum current	A	0.22	0.32	0.36	0.52	0.56
Maximum power	W	11	19	20	29	33
Weight VS	kg (lbs)	18 (40)	21 (47)	25 (55)	28 (62)	32 (71)
Weight VSI	kg (lbs)	10 (22)	13 (29)	17 (38)	20 (44)	24 (53)

IP units are converted from SI equivalent – all IP units nominal

1.5 Dimensions

2 PIPES – VS						
Dimensions	Model	VS 7-2P	VS 9-2P	VS 11-2P	VS 13-2P	VS 15-2P
A	mm (inch)	735 (29)	935 (37)	1135 (45)	1335 (53)	1535 (61)
a1	mm (inch)	210 (9)	310 (13)	410 (17)	510 (20)	610 (24)
a2	mm (inch)	254 (10)	354 (14)	454 (18)	554 (22)	654 (26)

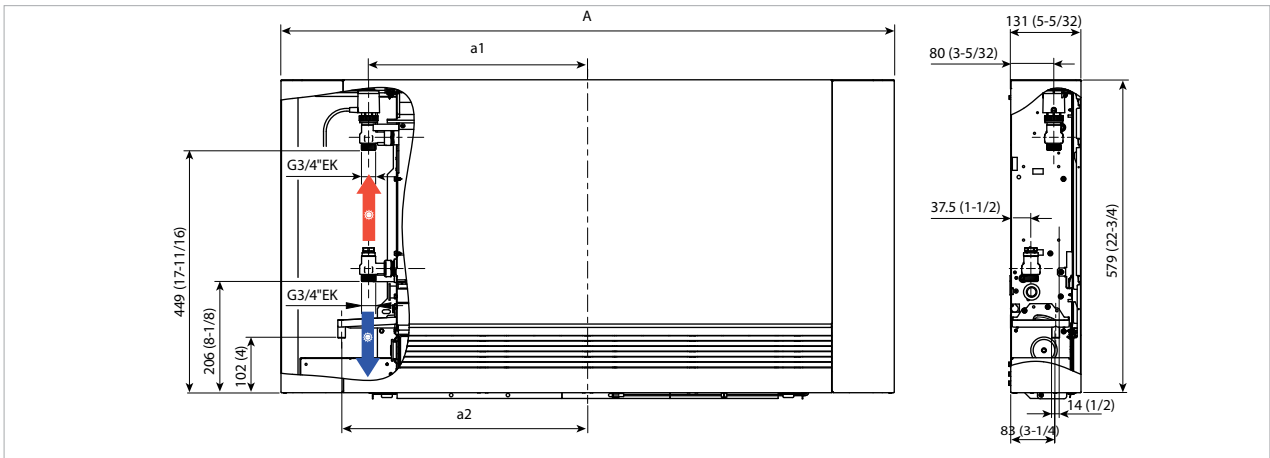

2 PIPES – VSI						
Dimensions	Model	VSI 7-2P	VSI 9-2P	VSI 11-2P	VSI 13-2P	VSI 15-2P
A	mm (inch)	378 (14-7/8)	578 (22-3/4)	778 (30-5/8)	978 (38-1/2)	1178 (46-3/8)

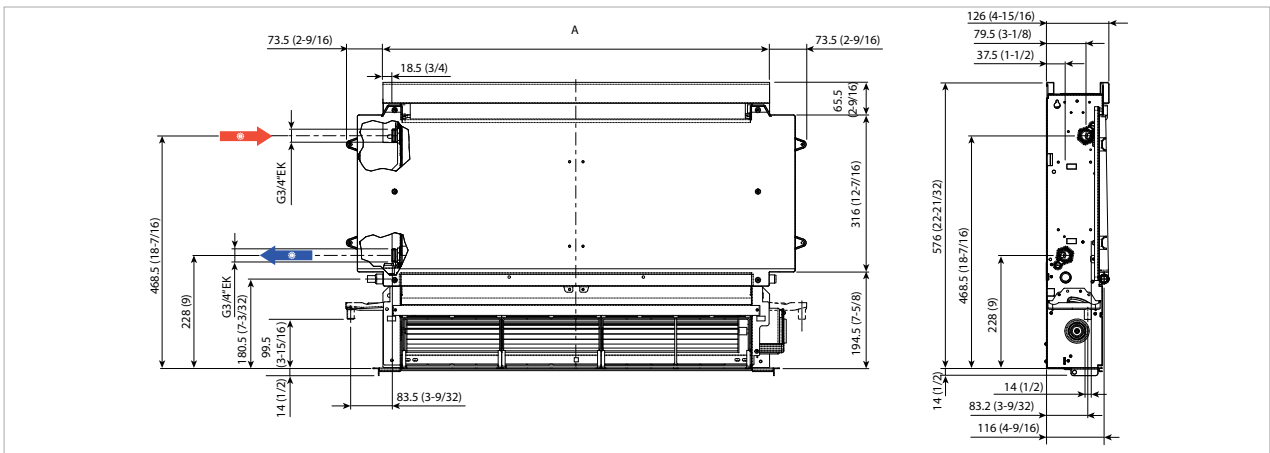

2-pipe inset unit shown without factory-fitted valves. For more details see section 4 below.

4 PIPES – VS						
Dimensions	Model	VS 7-4P	VS 9-4P	VS 11-4P	VS 13-4P	VS 15-4P
A	mm (inch)	735 (29)	935 (37)	1135 (45)	1335 (53)	1535 (61)
a1	mm (inch)	210 (9)	310 (13)	410 (17)	510 (20)	610 (24)
a2	mm (inch)	254 (10)	354 (14)	454 (18)	554 (22)	654 (26)

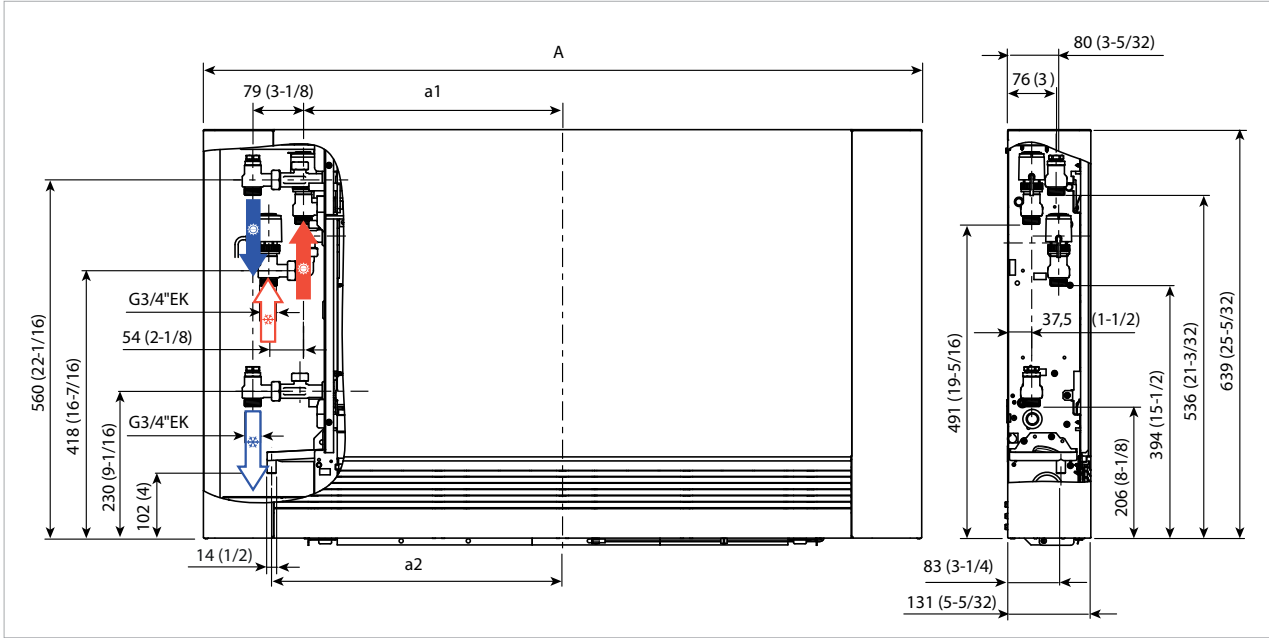

4 PIPES – VSI						
Dimensions	Model	VSI 7-4P	VSI 9-4P	VSI 11-4P	VSI 13-4P	VSI 15-4P
A	mm (inch)	378 (14-7/8)	578 (22-3/4)	778 (30-5/8)	978 (38-1/2)	1178 (46-3/8)

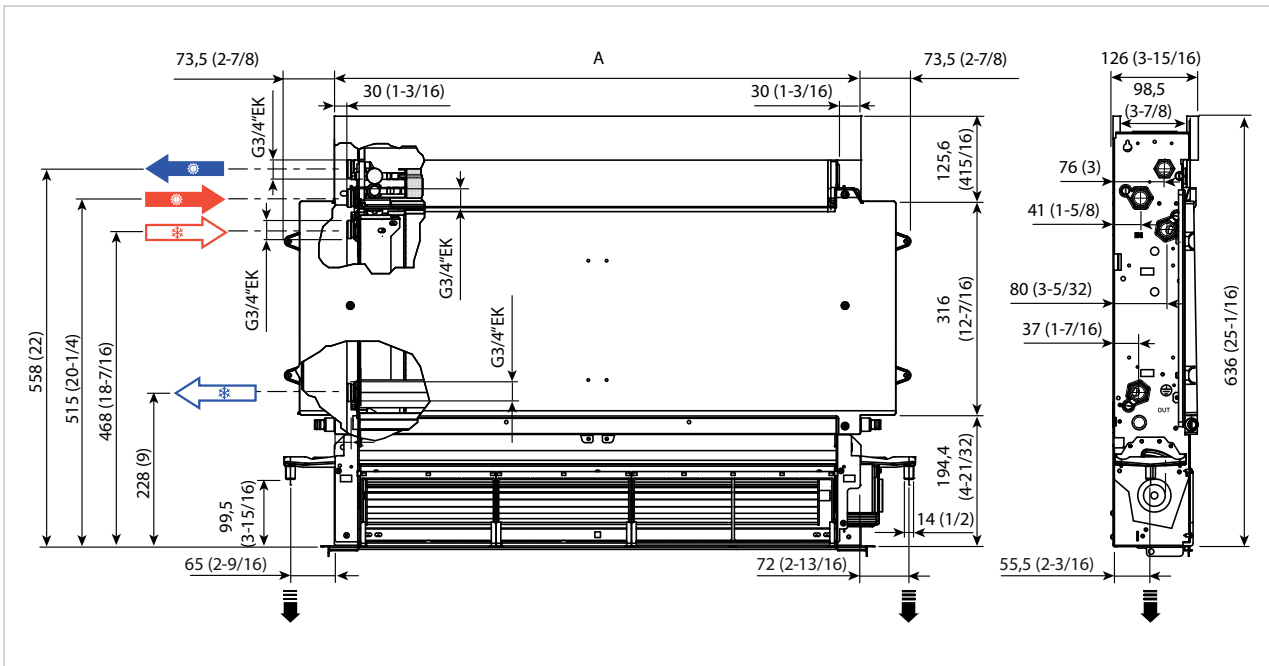

4-pipe inset unit shown without factory-fitted valves. For more details see section 4 below.



Installation

2.1 Positioning the unit

This unit must not be installed in a bathroom, in damp areas or places with possible contact with water.

Avoid installing the unit:

- ⚠ in positions subject to exposure to direct sunlight;
- in proximity to sources of heat;
- in places with oil fumes
- in places subject to high frequency radio waves

The following instructions refer to units with standard water connections on the left hand side.



Make sure that:

- the surface on which the unit is to be installed is strong enough to support the weight;
- the installation does not interfere with existing pipes or electric wires ;
- the surface is perfectly flat;
- that the air inlet and outlet are free of obstructions;
- the installation surface is preferably near an external wall to allow the discharge of the condensate outside;
- in case of ceiling installation (VS or VSI version) the airflow is not directed towards room occupants

2.2 Installation clearances

The figure below indicates the minimum clearance between the surface-mounted unit and any adjacent furniture.

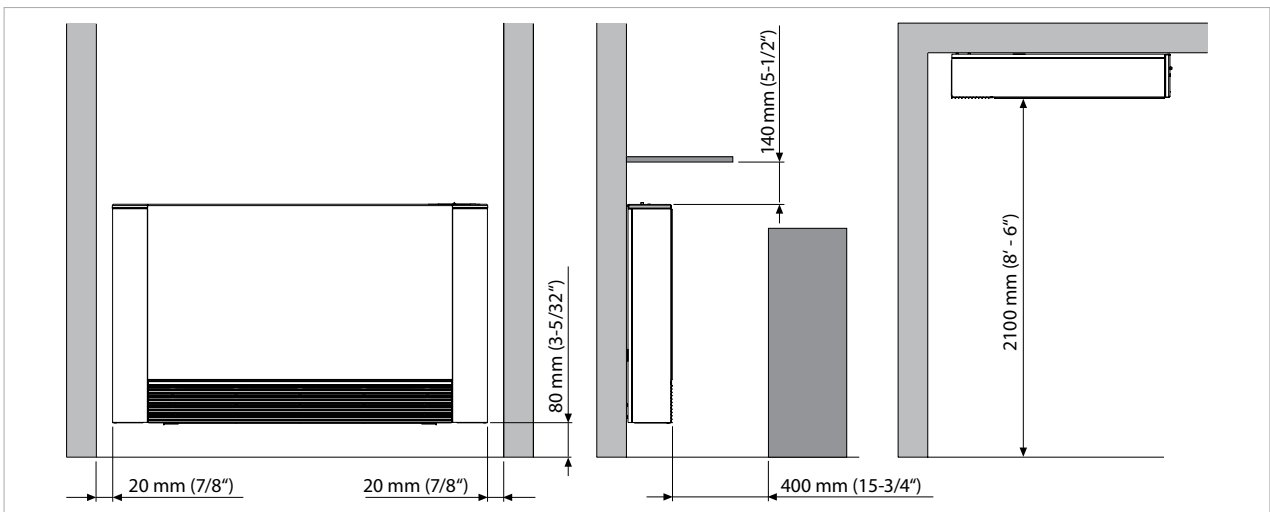

2.3 Side opening

- On the left-hand side, lift the cover that protects the screw, loosen the screw that fixes the left panel, then move it slightly to the left and lift it up.

- A Cover
- B Fixing screws

- On the opposite side, lift the cover that protects the screw and unscrew it.
- Move the side panel slightly to the right and lift it out.

- C Left panel
- D Right panel

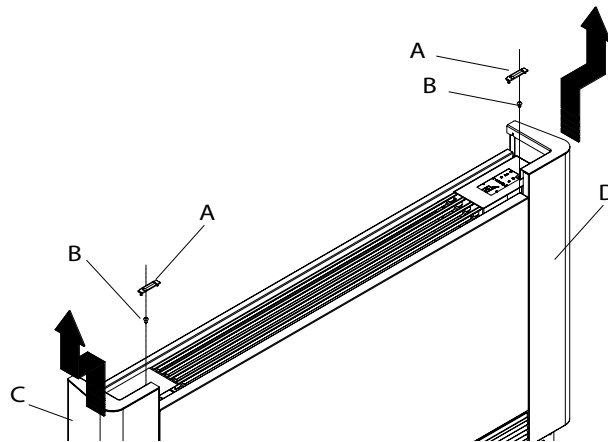

2.4 Vertical floor or wall installation

When mounting on the floor with support feet, refer to the product instructions supplied, and the instructions supplied with the support feet.

Use the paper template provided to trace the position of the bracket fixing holes on the the mounting surface. Drill the holes, insert the mounting plugs or other suitable fixing and secure the 2 brackets.

Do not over-tighten the screws, check alignment with a spirit level and make final adjustment. Mark the lower fixing points, remove unit, then drill and plug mounting surface. Fully tightening the bracket screws, refit unit, check alignment and stability then secure using bottom screw fixings.

NOTE: take care to ensure correct orientation of the mounting brackets. These should be fixed with small tabs pointing towards the fixing surface.

A Mounting plugs

B Brackets

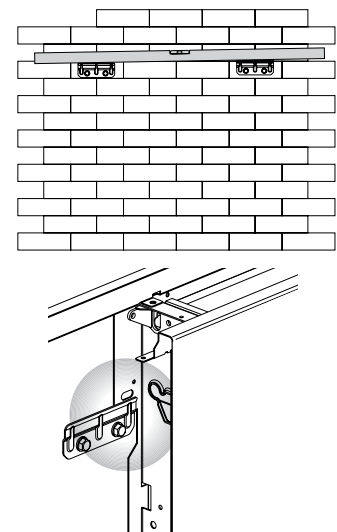
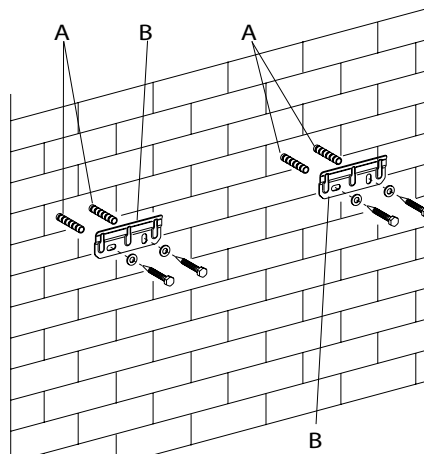
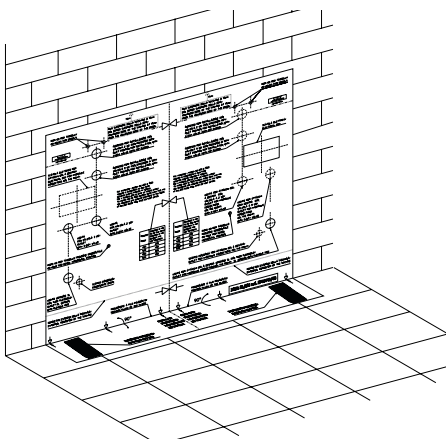

2.5 Horizontal or ceiling installation (VS, VSI)

Using the paper template provided, trace on the ceiling the position of the two fixing brackets and the two rear screws. Using a suitable drill, make the holes and insert the mounting plugs (2 for each bracket). Fix the two brackets. Do not over-tighten the screws. Position the unit on the two brackets, keeping it in position and then fix the two screws into the rear toggle bolts, one on each side.

drainage. Additional washers or spacers may be needed.

Fully tighten all 6 fixing screws.

For installation of the VS versions, horizontal condensation collection tray accessory kits are available.

⚠ Make sure that there is sufficient inclination of the unit towards the drainage pipe to facilitate the water

⚠ Carefully check the inclination of the condensate pipe. Any backflow can cause water leakage.

- A Mounting plugs
- B Brackets

- C Screws
- D Drainage pipe

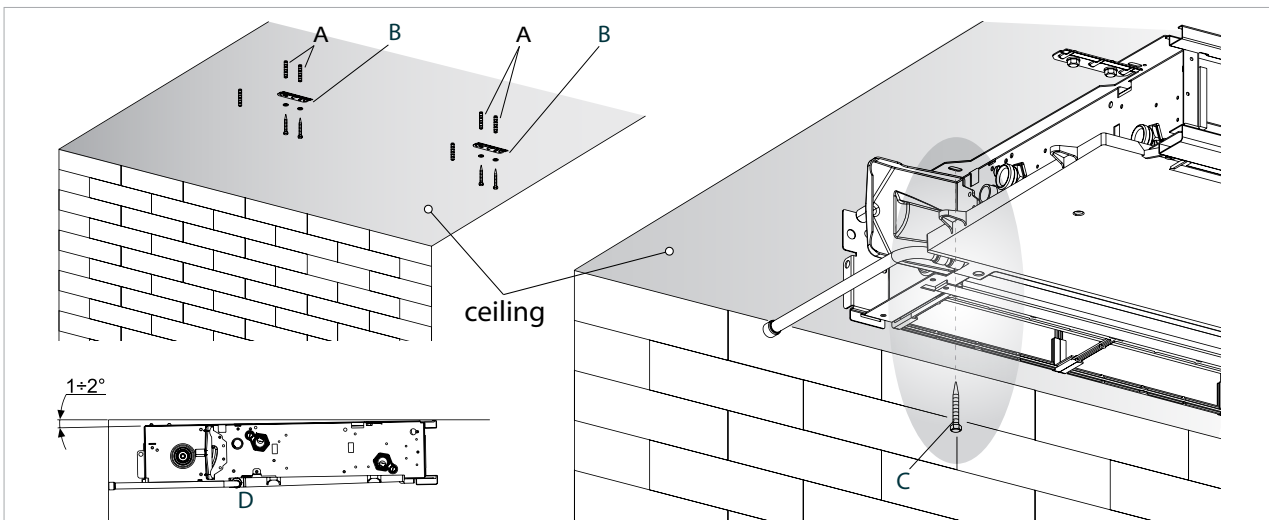

2.6 Mounting front grille safety support (VS)

When the unit is installed horizontally the inlet grille must be attached to the chassis using the two tie straps supplied in the accessory bag. This prevents the grille from falling and ensures safe filter replacement.

Separate the two tie straps then;

- Remove the front grille and completely unscrew the spring-loaded fixing screws.
- Fix one end of each tie to the chassis using the spring-loaded fixing screws.
- Fix the other end of each tie to the grille using the supplied screws.
- Refit the grille.

- A Ties
- B Spring-loaded screws

- C Screw fixing

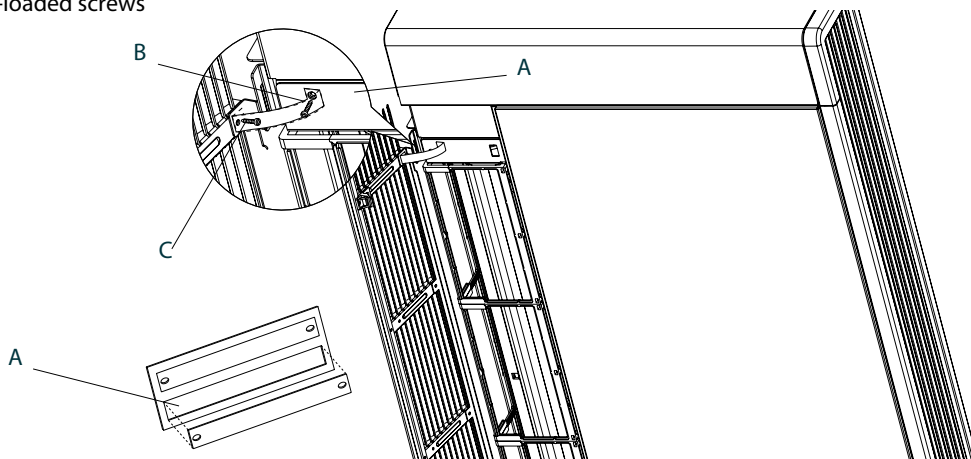

2.7 Air intake grille fixing

If the inlet grille is accidentally removed or left loose the fan will stop and the grille safety alarm will activate. To prevent this from happening the grille can be secured using the 2 screws provided (type TC 4,2x9,5 mm).

Fit the grille and secure by fitting the 2 fixing screws into the dedicated holes located on the grille's fixing bars as shown below.

- A Insert grille tab into lower bracket slot
- B Fixing screws

- C Correct position of grille tab

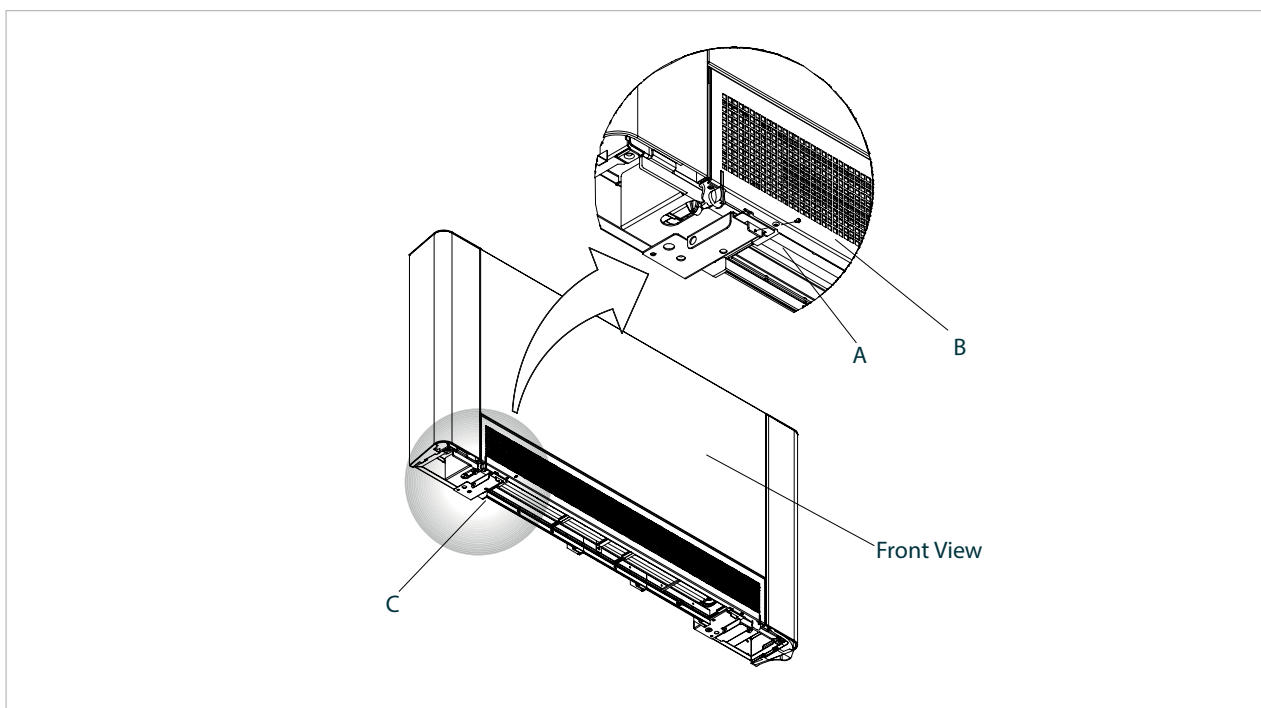

2.8 Water connections

MINIMUM PIPELINE DIAMETERS					
Model	VS 7-2P	VS 9-2P	VS 11-2P	VS 13-2P	VS 15-2P
	VSI 7-2P	VSI 9-2P	VSI 11-2P	VSI 13-2P	VSI 15-2P
	VS 7-4P	VS 9-4P	VS 11-4P	VS 13-4P	VS 15-4P
	VSI 7-4P	VSI 9-4P	VSI 11-4P	VSI 13-4P	VSI 15-4P
Minimum Pipeline diameters mm (inch)	14 (1/2)	14 (1/2)	16 (1/2)	18 (3/4)	20 (3/4)

The system should be designed and installed following best practice by a qualified installer. The choice and sizing of the pipework should take into account the number and size of the units installed, and the performance characteristics of each unit. Undersized pipes can cause malfunction of the units. A suitable thread sealant should be used. The use of Teflon thread sealant is advised when there is anti-freeze in the hydraulic circuit.

The water connection pipes and joints must be thermally insulated.

Partially insulating the pipes should be avoided and the insulation should not be over-tightened.

After making the water connections check for leaks and cover the connections with insulating material.

2.9 Condensate discharge

The condensate discharge pipes must be suitably sized (minimum inside pipe diameter 16 mm / 1/2") and the pipeline positioned so that it keeps a constant inclination, never less than 1%. In a vertical installation, the discharge pipe is connected directly to the discharge tray, positioned underneath the water connections. In a horizontal installation the discharge tube is connected to the one already present in the unit. For installation of the VS versions in a horizontal position, horizontal condensation collection tray accessory kits are available.

- If possible, the condensate pipework should be directed into a rainwater discharge.
- When discharging directly into the main drains, it is essential to make a siphon to prevent bad odours coming up the pipe into the room. The curve of the siphon must be lower than the condensation collection bowl.

- If the condensate needs to be discharged into a container, the container must be open to the atmosphere and the tube must not be immersed in water so that the normal outflow is not restricted.
- If there is a height difference that could interfere with the outflow of condensate, a pump must be fitted:
- In a vertical installation mount the pump under the lateral drainage tray.
- In a horizontal installation the pump position must be decided according to the specific requirements.

Such pumps are readily available.

On completion of the installation, it is advisable to check the correct outflow of the condensate by slowly pouring about 0.5 l (0.5 quarts) of water into the collection tray in about 5-10 minutes.

Condensate discharge pipe connection – vertically mounted units

Check that the condensate collection tray is present and is correctly installed.

Connect the discharge pipe (B) to condensate collection tray (A).

A Discharge fitting

B Condensate pipework

C Internal discharge point

D Condensate collection tray

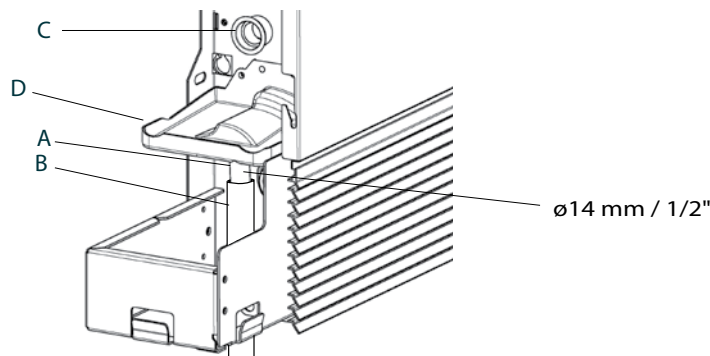

Condensate discharge pipe connection – horizontally mounted units

To mount the horizontal condensate tray on the VS units refer to the instructions supplied with accessory kits.

- Check that the "L" pipe (A) and the flexible rubber hose are correctly connected to the condensate tray.
- Slide in the side of the unit keeping the pipe in position up against the front grille.
- Fully close the side checking that the pipe remains tight in the special groove on the side.

N.B. for a horizontal installation carefully note the following precautions:

- Make sure that the unit is installed perfectly level or with a slight inclination towards the condensate discharge point.
- Carefully insulate the flow and return pipes to the unit to prevent any drops of condensate falling outside the drip tray.
- Insulate the condensate discharge pipe (B) along its complete length.

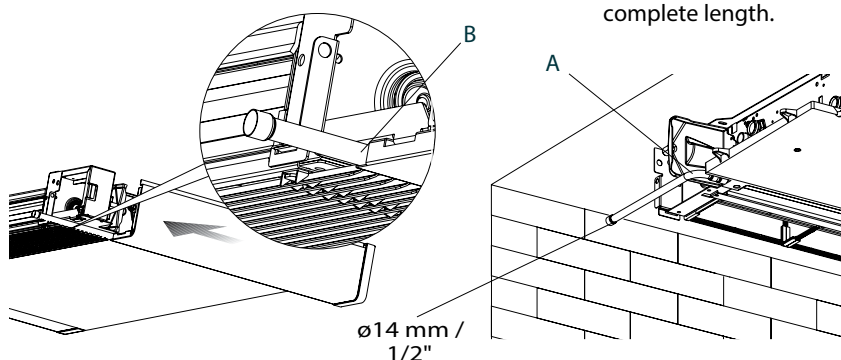

2.10 Filling and venting the system

When starting up the system, make sure that the return valve is open. Refer to section 4.3 for correct setting. If there is no electric power and the valve actuator has not already been powered up, use the special tool, press the valve actuator and use the tool to keep it open.

- Open all the shut off valves (manual or automatic).
- Start to slowly fill the system.
- For units installed in a vertical position, open the highest vent of the heat exchanger; for appliances installed in a horizontal position, open the highest

positioned vent; for the 4-pipe versions open the highest vents on both heat exchangers. Vents can be opened using a screwdriver.

- When water starts coming out of the air vents, close them and continue filling the system until reaching the nominal system pressure.
- Check for leaks.

It is advisable to repeat these operations after the appliance has been running for a few hours and to periodically check the system pressure.

A Venting of the heat exchange

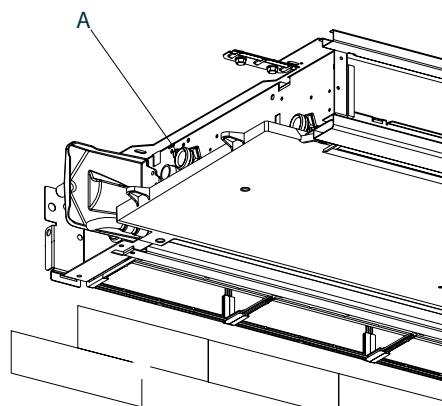
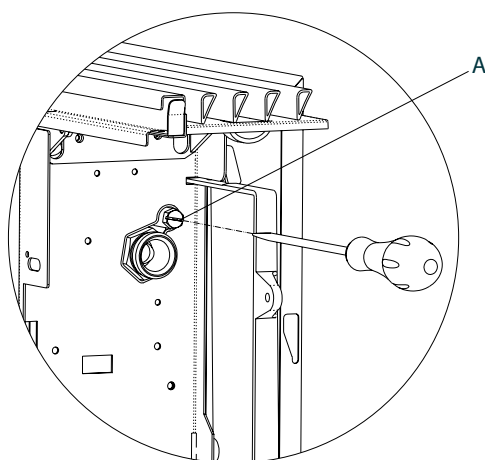

Warning: Commissioning instructions – opening the valve actuator (where used)

⚠ Remove the 'red plastic' clip from the valve actuator before starting the system.

- A Valve actuator
- B Valve

- C Red plastic clip

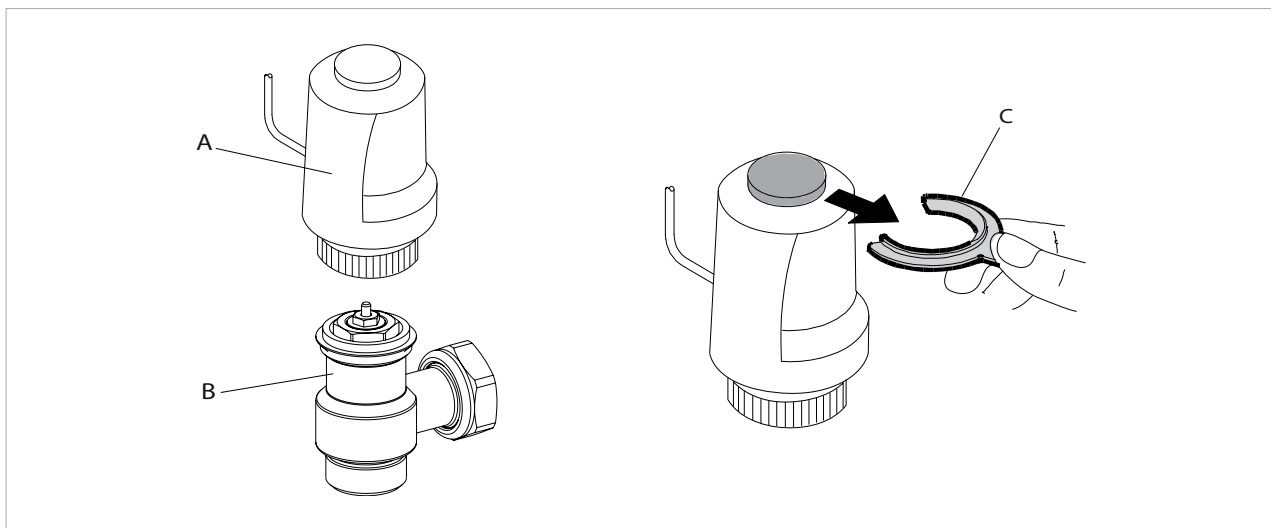

2.11 Electrical connections

- ⚠ Electrical connection must be made by a qualified electrician in accordance with local and national wiring regulations.
- ⚠ The unit must be connected to the mains supply using a switched fused spur having 3 mm / 1/8" separation on all poles.
- ⚠ This appliance must be earthed.

- Switch off electrical supply before making electrical connections.
- Remove control box cover.
- Make electrical connections to pcb.
- Secure power supply cables using strain relief clamps attached to the control box.
- Refit control box cover.

2.12 Maintenance

Routine maintenance is essential to keep this product in a safe and reliable working condition. End user maintenance activities should be limited to cleaning of the outer casing

and cleaning of the air filter at appropriate intervals. Any other repair or maintenance activity should be carried out by a qualified installer.

2.13 Cleaning the outer casing

- ⚠ Disconnect electrical supply before carrying out any cleaning or maintenance activities.
- ⚠ Do not use abrasive cloths or abrasive or corrosive detergents to avoid damaging the painted surfaces.
- ⚠ Wait until the parts have cooled down to avoid the risk of burns. When necessary, clean the outer surfaces of the iVector S2 with a soft damp cloth.

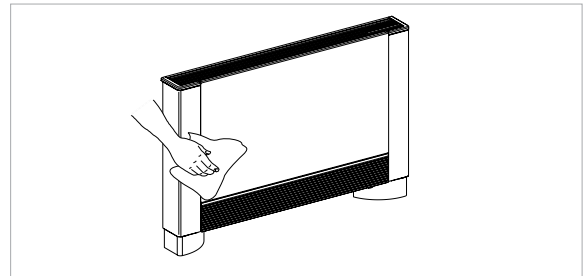

2.14 Cleaning the air filter

To maintain air flow levels through the unit, air filters should be cleaned at regular intervals. The frequency of cleaning should take into consideration the

concentration of impurities in the local environment and duration of operation. Filter cleaning should also be considered after a period of inactivity.

Removing the filter

- Remove the front grille by lifting it slightly and turn it until it comes completely out of its seat.

- Remove the filter by pulling horizontally outwards.

- A Lift front grille
- B Rotate grille forward

- C Filter exposed
- D Remove filter

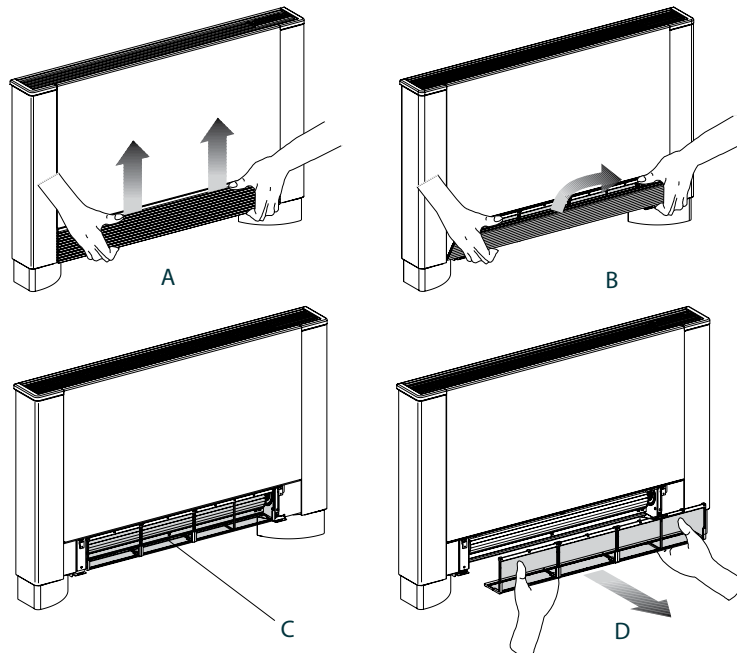

Cleaning the filter

- Remove any dust with a vacuum cleaner.
- Wash the filter with clean running water. Do not use detergents or solvents.
- Leave to dry.
- Re-fit the filter taking care to insert the lower back edge into its seat.

Never use the unit without filters

- ⚠ The appliance is fitted with a safety switch that prevents operation of the fan with the front grille missing or out of position.
- ⚠ After refitting the filter, check that the grille is correctly mounted.

A Filter

B Lower edge

C Filter locating channel

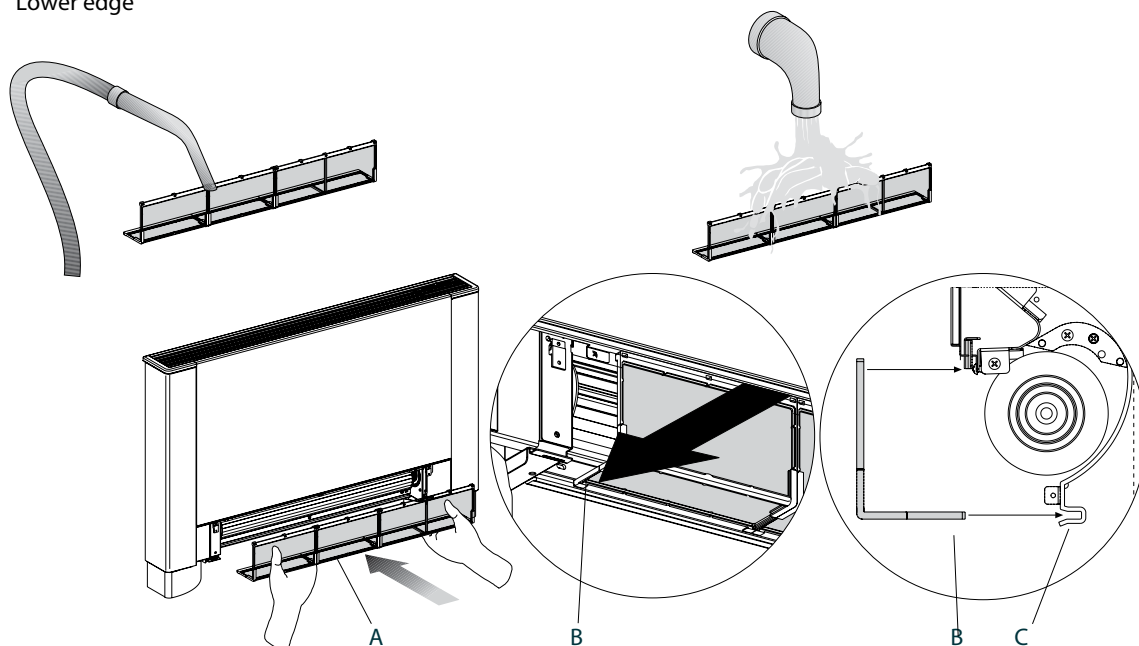

- To refit the grille, insert the two lugs into the lower slots, rotate it and attach to the upper chassis slots.

A Tabs

B Slots

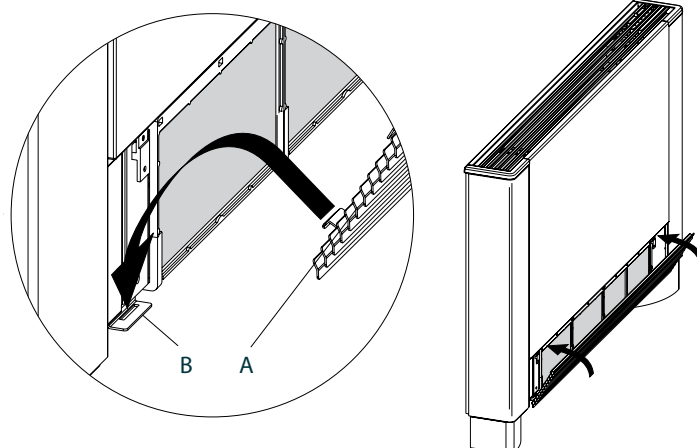

Energy saving tips

- Always keep the filters clean and as far as possible keep the doors and windows closed in the room being conditioned when the unit is in use.
- Limit where possible the effect of direct sun rays in the rooms being conditioned (use curtains, shutters etc.)

US Faults and Troubleshooting

3.1 Troubleshooting

⚠ In the event of a water leak or malfunction immediately cut off the power supply and close the system valves to the unit.

⚠ Should one of the following faults occur, contact a qualified installer. DO NOT intervene personally.

- the fan does not activate even if there is hot or cold water in the hydraulic circuit.
- the appliance leaks water during the heating function.
- the appliance leaks water only during the cooling function.
- the appliance makes an excessive noise.
- condensate forms on the front panel.

3.2 Fault-finding guide

These operations must be carried out by a qualified installer or by a specialised service centre.

EFFECT >	CAUSE >>	SOLUTION
A delayed fan start up following set temperature change or change of function.	The unit valves need time to open and as a result the hot or cold water takes time to circulate in the appliance.	Wait for 2 or 3 minutes for the unit valves to open.
The fan does not function	No hot or cold water in the system.	Check that the boiler or chiller are functioning correctly.
The fan does not activate even if there is hot or cold water in the hydraulic circuit.	The hydraulic valve remains closed	Remove the valve actuator and check if water circulation is restored. Check the valve actuator by powering it from a separate 230V (120V Canada/ US) source. If it activates then check the electronic control.
	The fan motor is blocked or burnt out.	Replace motor.
	The micro-switch that stops the fan when the filter grille is opened does not close correctly.	Check correct fitting of grille and that the micro-switch contact is activated.
	The electrical connections are not correct.	Check the electrical connections.
The appliance leaks water during the heating function.	Leaks in the hydraulic connections of the system.	Check the leak and fully tighten the connections.
	Leaks in the valve unit.	Check the condition of the gaskets.
Condensation forms on the front panel.	Front panel insulation damaged or detached.	Check the correct positioning of the thermo-acoustic insulation, paying attention to insulation in the front above the heat exchanger.
There are drops of water on the air outlet grille.	In situations of high humidity (>60%) condensation could form, especially at the minimum fan speeds	As soon as the humidity starts falling the phenomenon disappears. In any case the presence of a few drops of water in the appliance does not indicate a malfunction.
The appliance leaks water only during the cooling function.	The condensate tray is blocked.	Slowly pour a bottle of water into the low part of the heat exchanger to check the drainage; if necessary, clean the tray and/ or increase the inclination of the drainage pipe.
	The condensation discharge does not need an inclination for correct drainage.	
	The connection pipes and the valve unit are not insulated well.	Check the insulation of the pipes.
The appliance makes a strange noise.	The fan fouling adjacent parts.	Check if the filters are clogged and clean if necessary
	The fan is unbalanced.	An unbalanced fan can cause excessive vibrations in the unit; replace the fan.
	Check if the filters are clogged and clean them if necessary.	Clean the filters.

Instructions 2-way valve

4.1 Warnings

⚠ These instructions relate to the valve kits supplied with the unit. The general instructions and basic safety rules detailed in this manual should be followed.

⚠ For correct operating performance of this unit, the flow and return pipework must be correctly fitted according to the detail provided in these instructions.

4.2 2-way valve parts list

- 1x automatic valve with thermoelectric head for VS and VSI models
- 1x return with presetting for correct balancing of the system.
- 1x Connection 3/4" Eurocone extension pipe (for use with pipe connection from floor)
- Insulation pieces are supplied loose when the product is supplied. These should be fitted to the flow and return valves once the pipework connections have been made.

Pipe connection from floor – with optional 3/4" EK extension

- | | | | |
|---|-------------------------------------|---|--|
| A | Valve actuator (optional Canada/US) | D | 3/4" Eurocone extension (optional – supplied as accessory) |
| B | 2-way valve | E | Floor penetration opening |
| C | Return valve connection | | |

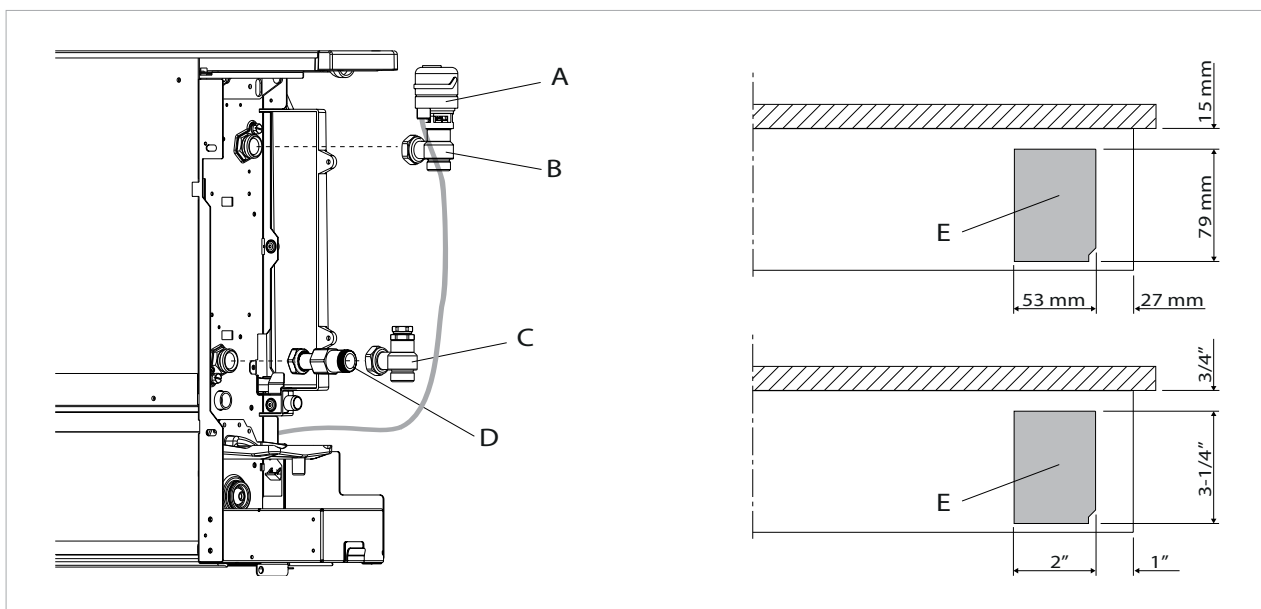

> PLEASE NOTE: valves are factory fitted but not tightened. For floor connections extension piece D (or similar) must be used to clear outside edge of condensate tray.

Pipe connection from wall – with optional 90° elbow fitting

- A Valve actuator
- B 2-way valve
- C 90° elbow fitting (optional – supplied as accessory)
- D Return valve connection

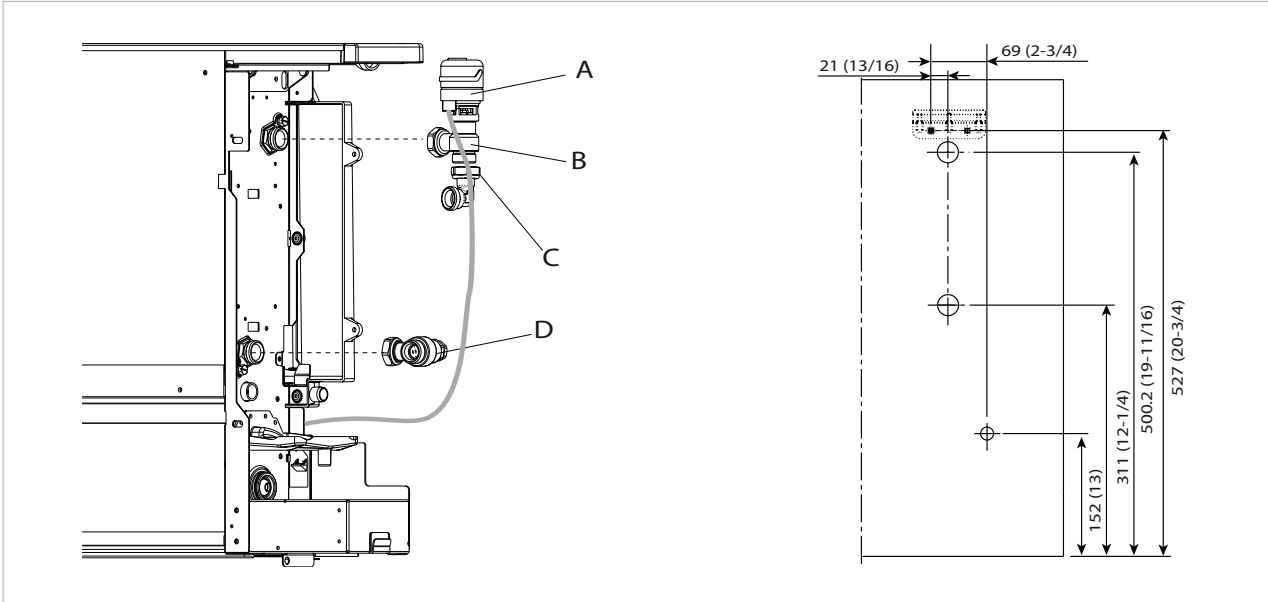

PLEASE NOTE: valves are factory fitted but not tightened. For through-the-wall connections 90° elbow C or similar should be used.

Pressure drop diagram

Pressure drop figures based on the 2 way valve fully open position.

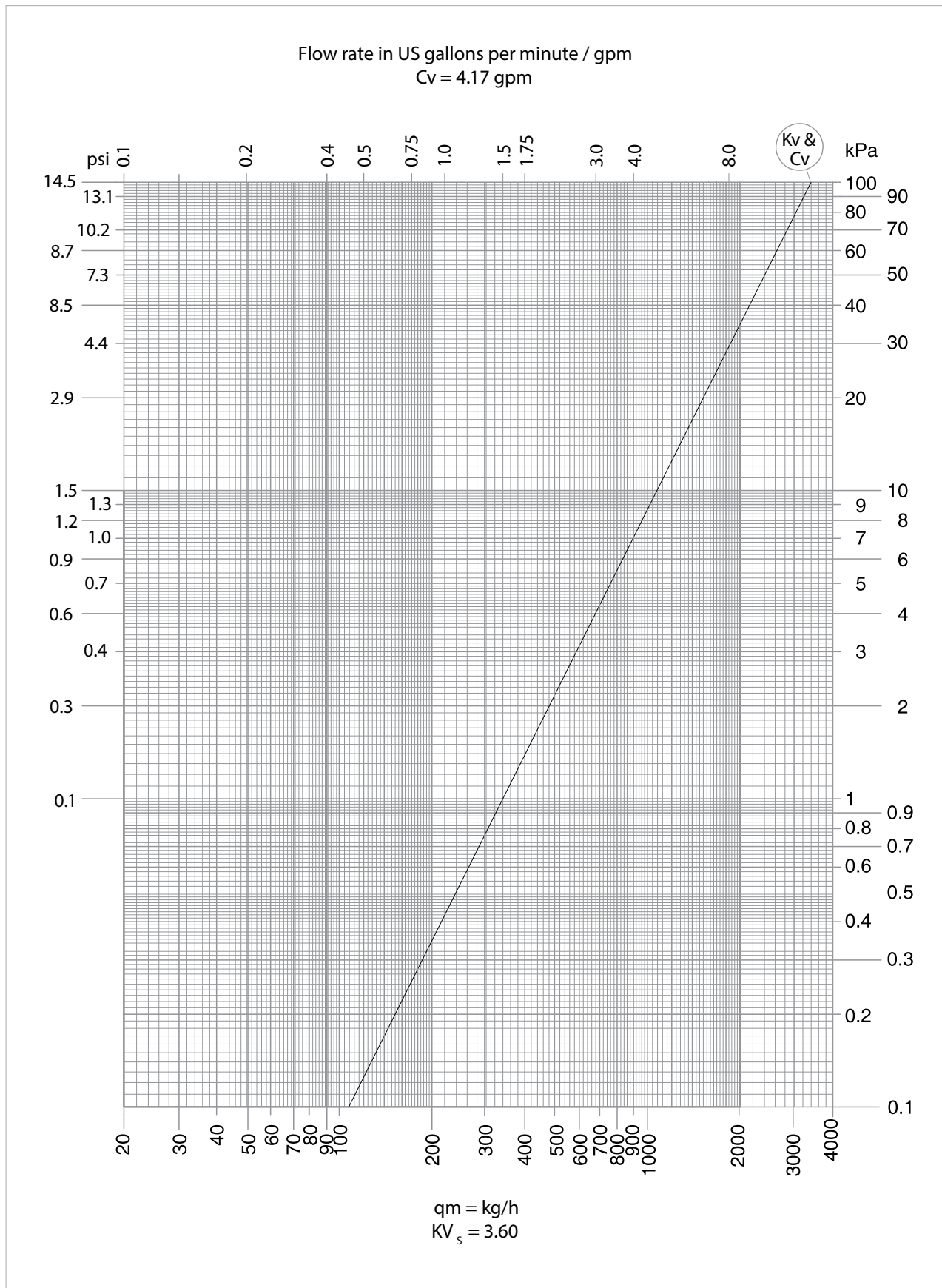

4.3 Return valve pre-setting screw adjustment

The system can be balanced using the return valve(s) fitted to the unit. The following procedure must be carried out for correct regulation and balancing of the system:

Return valve pre-setting adjustment:

- Remove the top cap to reveal the adjustment mechanism.
- Use a screwdriver to loosen and remove the slotted pin inside the central hexagonal recess.
- Use a 5mm Allen key to close the adjustment screw (A).

- Screw the slotted pin back in as far as it will go.
- Mark a reference point "x" aligned to the pin slot for adjustment of the pin. (B)
- Use the screwdriver to open up the pin. The number of turns should be determined from the ΔP -Q chart. (C)
- Use the Allen key to open up the adjustment screw as far as it will go. (D)
- The pre-setting is now done and does not change when opening and closing the adjustment screw with the Allen key. Replace the cap.

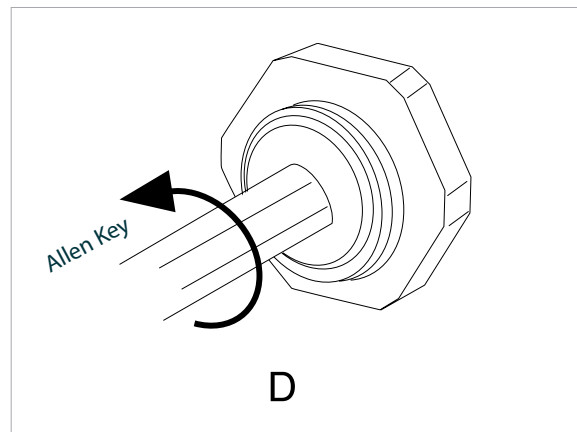
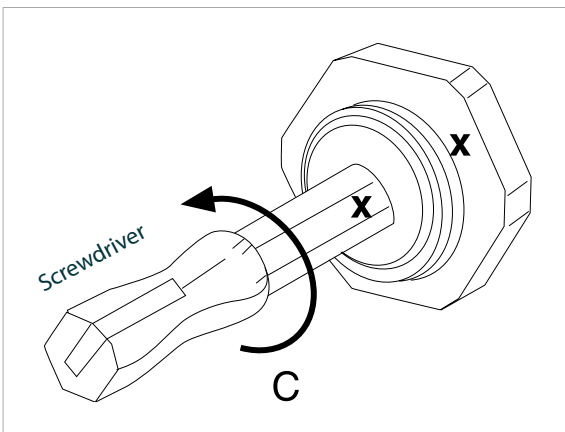
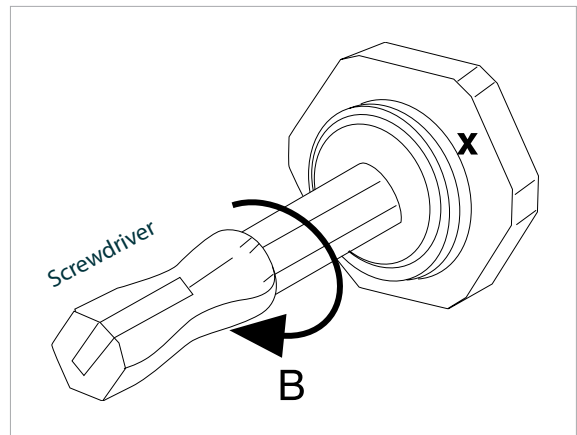
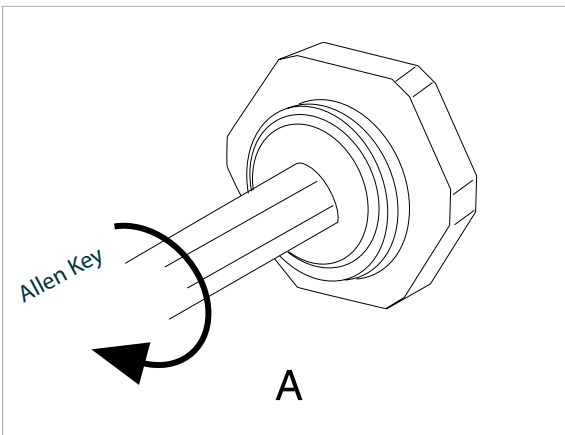

Pressure drop diagram

Pressure drop figures based on the return valve setting.

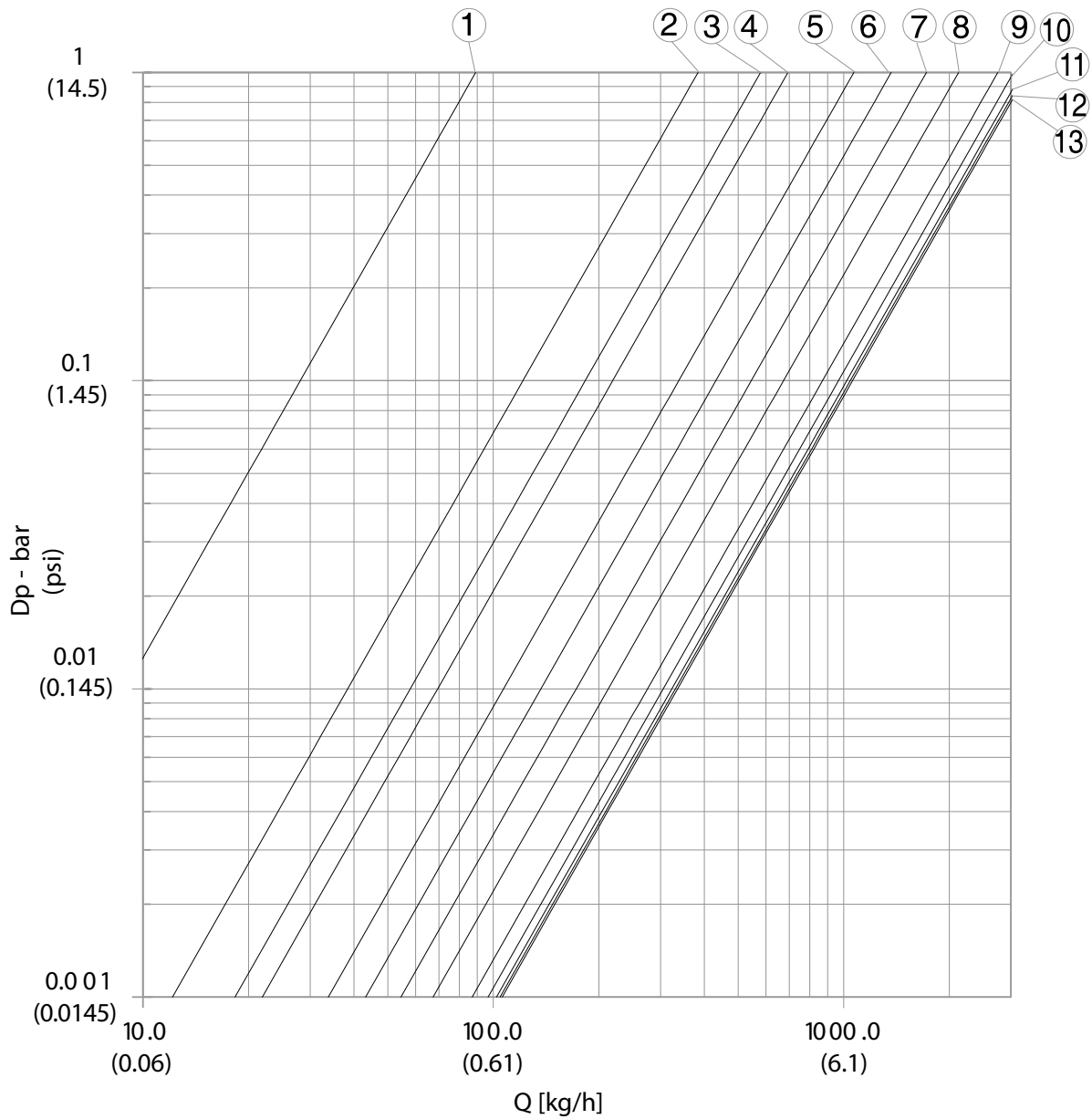

RETURN VALVE SETTINGS													
Pos.	1	2	3	4	5	6	7	8	9	10	11	12	13
Turns	1.25	1.5	1.75	2	2.25	2.5	2.75	3	3.5	4	4.5	5	5.5
Kv	0.09	0.38	0.58	0.69	1.07	1.37	1.72	2.13	2.75	3.06	3.23	3.31	3.35
Cv	0.10	0.44	0.67	0.80	1.24	1.59	1.99	2.47	3.18	3.54	3.74	3.84	3.88

4.4 Valve insulation

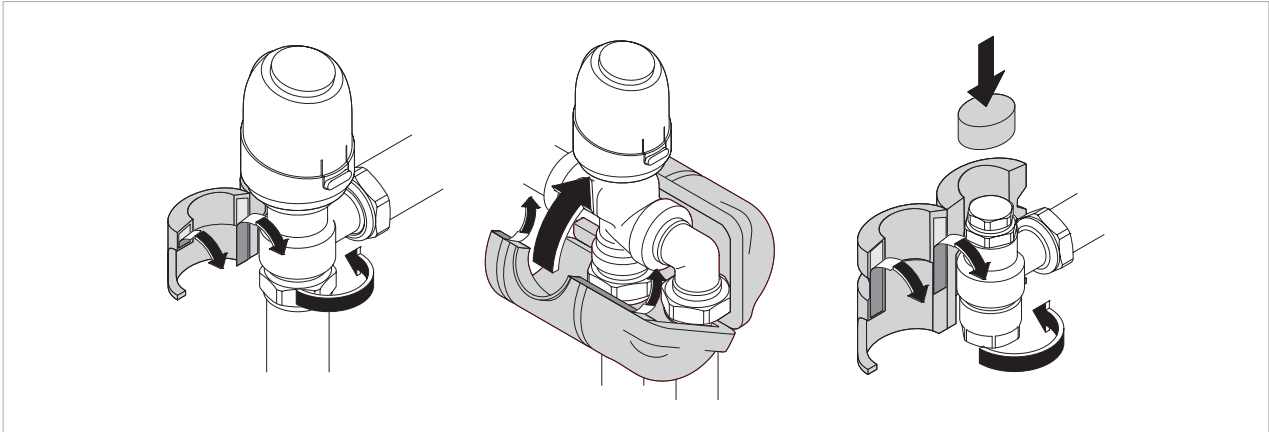

- ⚠ Water pipes and joints must be thermally insulated.
- ⚠ Avoid partial insulation of the pipework.
- ⚠ Check that the insulation is sufficiently tight to avoid condensation and dripping, but not too tight in case of damage to pipework.

Control panel connection and setup

5.1 Connection and setup of onboard control panel

The control panel on each unit has the following connection options:

- Voltage free contact output to chiller
- Voltage free output to boiler
- 2 pipe models – 230V relay output to heat / cool valve actuator (115V Canada/US)
- 4 pipe models – 230V relay output to heating valve actuator and 230V relay output to cooling valve actuator (115V Canada/US)
- Presence detector input.

A 10 k Ω water temperature probe attached to the heat exchanger controls fan operation. In heating the fan will operate when the water temperature reaches 30°C (86 °F), and in cooling the fan will operate when water temperature drops below 20°C (68 °F).

5.2 Cooling mode additional functionality

The cooling function can be changed using dipswitch B on the main control board. If dipswitch B is set to ON, the fan will continue to operate at minimum speed in cooling, even after the set point is reached. This allows for more uniform operation of the temperature probe

and prevents layering of the air. When dipswitch B is set to OFF, the unit will cycle 4 minutes on, 10 minutes off when the cooling set point is reached (the factory setting of switch B is off).

5.3 Night time heating additional functionality

The night time heating logic can be changed using dipswitch C on the main control board.

In the ON position, the fan will always be off and heating is by radiation and natural convection only.

In the OFF position the fan operates as normal (the factory setting of switch C is off).

Night time heating can be selected by pressing  on the control panel

5.4.2 Pipe & 4 pipe models with integrated control

H2*	water temperature probe (10 kΩ)
H4*	water temperature probe (10 kΩ) 4 pipe only
AIR	air temperature probe (10 kΩ)
M1	DC inverter fan motor
Y1	Valve actuator (230V/ 50Hz 1A output voltage) (115V/60Hz Canada/US)
Y2	4 pipe valve actuator (230V/ 50Hz 1A output voltage) (115V/60Hz Canada/US)
L-N	230V/50Hz electrical power supply (115V/60Hz Canada/US)
UV	UV lamp connection

BO	boiler switched output (voltage free contact max 1A)
CH	chiller switched output (voltage free contact max 1A)
CP	presence detector input (if closed, the fan coil unit is placed in standby)
*	After power on and with the unit is set for heating or cooling, the fan will only operate when the water temperature reaches 30°C (86 °F) in heating, or falls below 20°C (68 °F) in cooling.

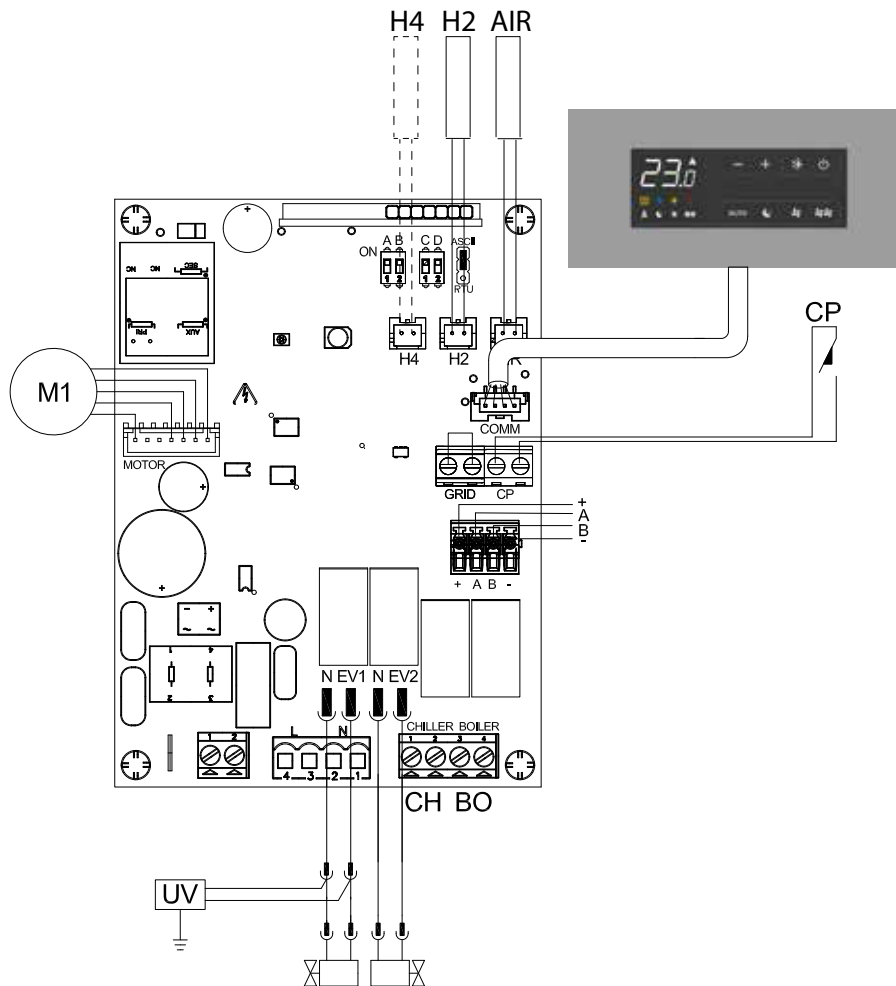

5.5.2 Pipe & 4 pipe models with remote-mounted control

+AB-	serial connection for wall-mounted remote control (respect AB polarity)
H2*	hot water temperature probe (10 kΩ)
H4*	cold water temperature probe (10 kΩ) air temperature probe (10 kΩ)
M1	DC inverter fan motor
Y1	Valve actuator (230V/ 50Hz 1A output voltage) (115V/60Hz Canada/US)
Y2	4 pipe valve actuator or 230V/50Hz 1A output voltage (115V/60Hz Canada/US)
L-N	230V/50Hz electrical power supply (115V/60Hz Canada/US)
UV	UV lamp connection

BO	boiler switch output (voltage free contact max 1A)
CH	chiller switch output (voltage free contact max 1A)
AIR	Air probe optional (**)
*	After power on and with the unit is set for heating or cooling, the fan will only operate when the water temperature reaches 30°C (86 °F) in heating, or falls below 20°C (68 °F) in cooling.
**	Alternatively, connect the air probe to the remote mounted control

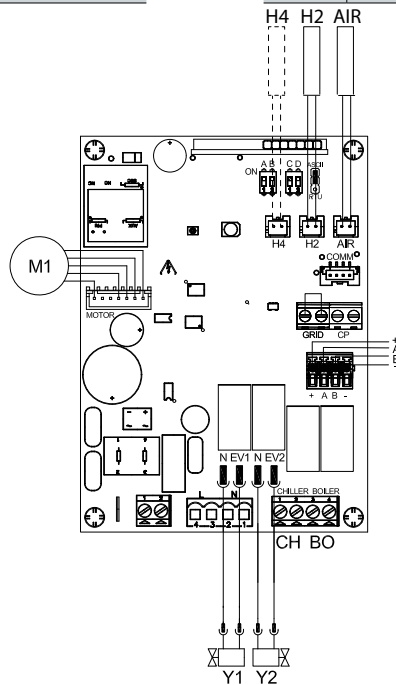

Electrical connection of the cable from the remote wall-mounted control should be made to the 4-way screw terminal block (A) on the unit control board. Use suitable cables as detailed in sections 6.2 and 6.3.

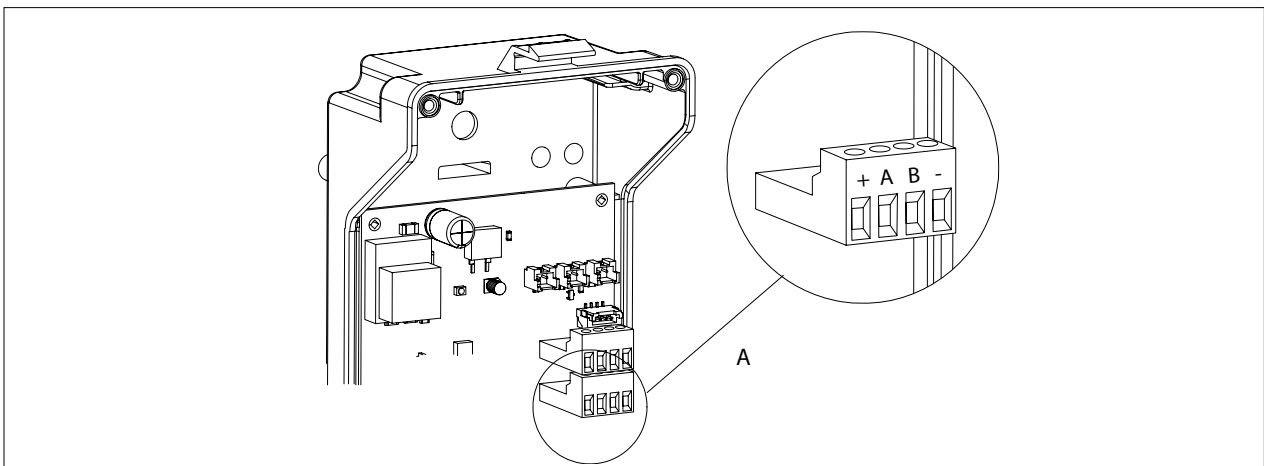

5.6 Connection of multiple units using remote-mounted thermostat

All functions of the fan coil can be controlled from a remote-mounted thermostat, and up to a maximum of 30 units can be controlled from one thermostat with simultaneous command to all units connected. The operational parameters, temperature set point and room temperature, are transmitted from the remote to all connected units to give unified operation.

Electrical connection should be made using a suitable two-core RS485 serial connection cable to terminals A and B, and two power supply cables to terminals + and -, keeping the power supply cables separate

- Where possible minimise the length of the leads used.
- Complete the installation with the 120Ω resistor supplied, as shown.

- Do not make star connections
- The RS485 should be a shielded two-core cable with a minimum thickness of 0.35mm².
- Ensure consistent wire connection to terminals A & B at the unit and at the wall-mounted control
- Connect the leads from the + and - power terminals on the wall mounted remote, 12V DC, to the unit circuit boards, ensuring consistent wire connection at each end.

The 10 kΩ water temperature probe attached to the heat exchanger controls fan operation. In heating the fan will operate when the water temperature reaches 30°C (86 °F), and in cooling the fan will operate when water temperature drops below 20°C (68 °F).

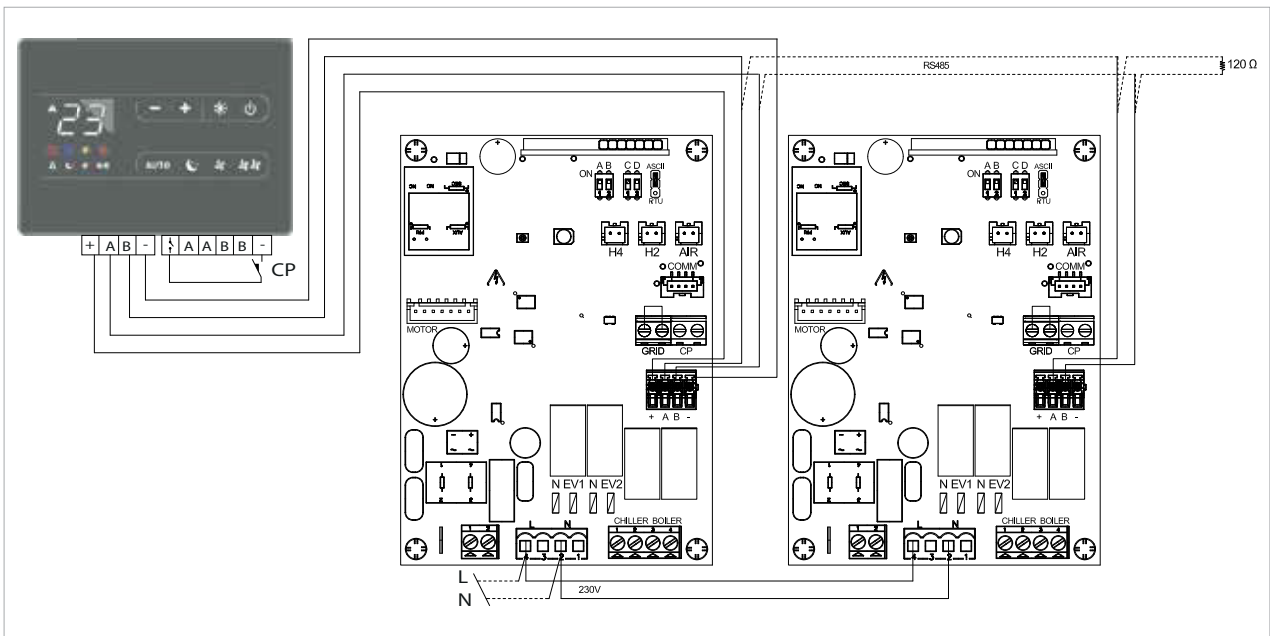

5.7 LED Indications (A) 2 pipe & 4 pipe models with remote mounted thermostat

The circuit board in each unit has a green LED that indicates operational status and any fault conditions.

- Green LED: Indicates that the unit is operational. Flashing indicates a fault.
- LED off: unit is off or has no power.

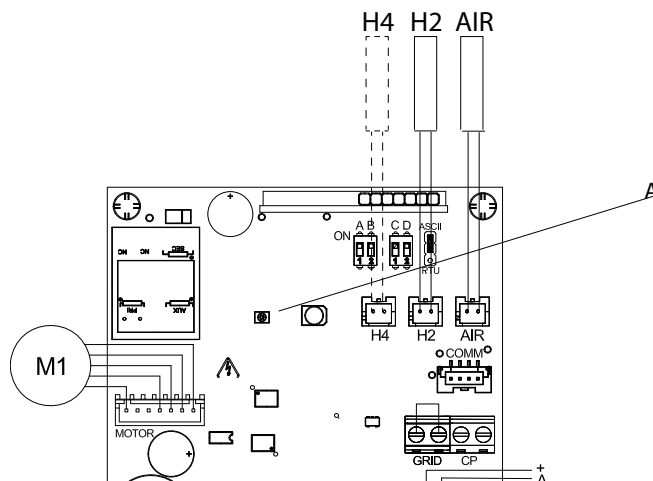

ERROR MESSAGES

Error	Display
Communication error. The circuit board expects continuous information exchange on the serial line with the wall-mounted control. If this exchange is lost for more than 5 minutes, an error warning is displayed, and the unit deactivated.	6 flashes + pause
Problem with fan motor (e.g. blockage caused by foreign objects, faulty rotation sensor).	2 flashes + pause
Water temperature probe fault for 2-pipe versions (H2). In this case, ensure that the probe installed is 10 kΩ.	3 flashes + pause
Cold water temperature probe fault for 4-pipe versions (H4) positioned on the main heat exchanger.	5 flashes + pause
Grille contact open	Continuous rapid flashing
Water demand detected by probe H2 insufficient (above 20°C (68 °F) when cooling, below 30°C (86 °F) when heating). Stops the fan until the temperature returns to a suitable level to satisfy the demand*.	1 flashes + pause
Only for 4-pipe units: cold water demand detected by probe H4 insufficient (above 20°C (68 °F)). Stops the fan until the temperature returns to a suitable level to satisfy the demand*.	4 flashes + pause

* If after having powered up the board the water probe is detected, start-up takes place according to the minimum and maximum water temperature thresholds.

5.8 Remote-control panel mounting

The wall-mounted remote-control is an electronic thermostat (fitted with an optional temperature probe which can be remotely installed in one of the fan coils connected to it) with the possibility to control one or more units (up to max. 30) fitted with an electronic controller for remote control.

Install the wall-mounted remote-control away from doors and/or windows and from heat sources (radiators, fan coils, hobs, direct sunlight), on internal walls and around 1.5m (60 inches) from the floor.

The wall-mounted remote control is inside the pre-assembled package. Prior to fixing to the wall, the two parts should be separated by unhooking the two protruding teeth on the rear (A). Use the base of the controller (B) to trace the fixing points on to the wall (use two opposing holes). Then proceed with the following operations:

- drill holes in the wall.
- pass the cables through the opening in the base.
- fix the base of the controller to the wall using suitable screws and mounting plugs.
- make the electrical connections then close the controller taking care not to trap any of the wires.

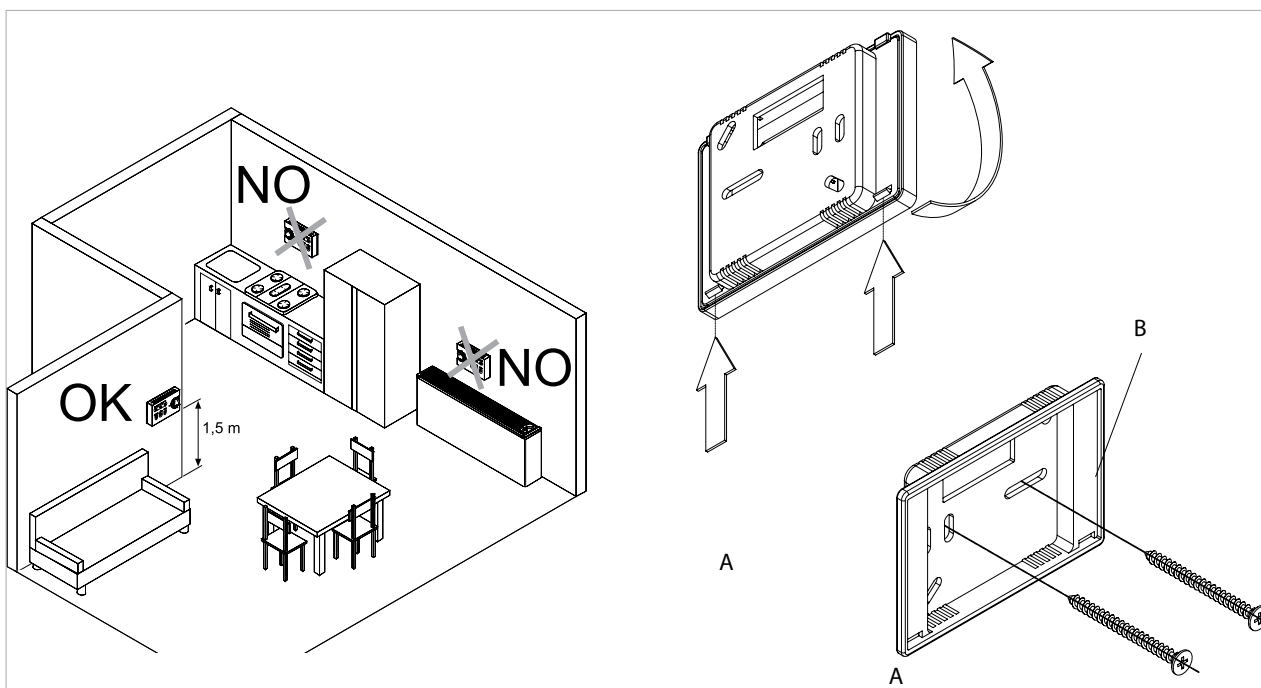

5.9 Wiring connection to remote-mounted control

Wiring connection to the remote-mounted control is made by inserting wires into the spring-loaded terminals on the back of the control. RS485 cable should be used to connect to terminals A and B, and 0.2 to 1.0mm² (18 gauge) rigid or flexible wires into the + - power terminals (see section 6.3).

- Strip back wires by 8mm (about 5/16 inches).
- Insert in to terminals and check correct connection by pulling gently.
- To remove from terminal, press white tab (C) to release conductor

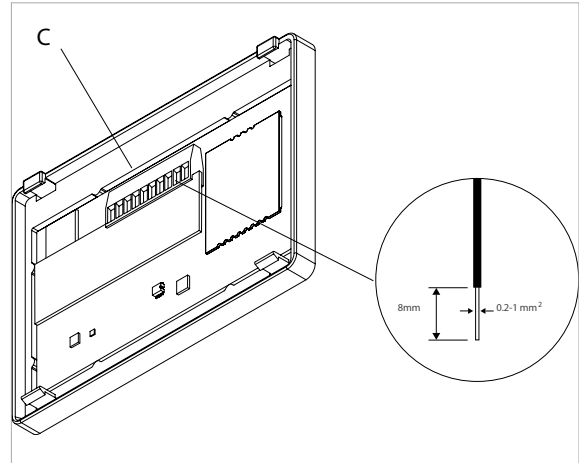

5.10 Presence detection sensor input connection – units with remote-mounted control

This unit can be equipped with a presence detector for rooms of infrequent use e.g. hotel rooms. Presence detector sensors are commercially available.

When the CP input contacts close, the units are placed into stand-by. If the contact is open the units are active. If the contact is closed, the units are

deactivated and when a key is pressed the  symbol flashes. The input cannot be connected in parallel to that of other electronic boards (use separate contacts).

- A Remote control terminal block
-  Contact CP

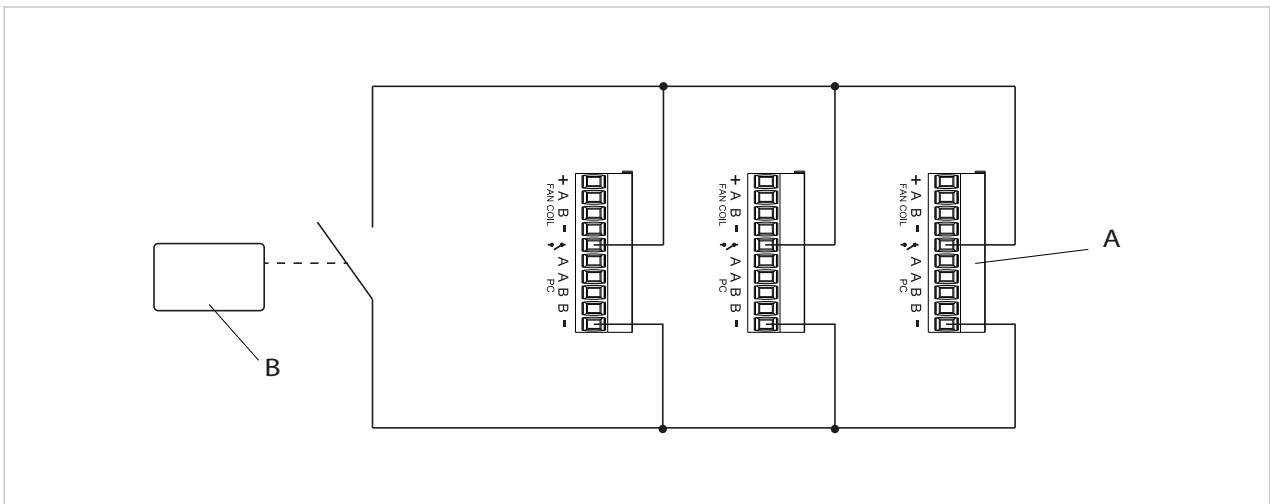

- B Auxiliary relay
- Contact





Onboard and remote control setup menu

6.1 Setup menu

The Setup Menu can be accessed through the remote control with the display switched off

Key	Operation	Display
	<ul style="list-style-type: none"> press the key "ON" for 10 sec the device turns on and the temperature appears continue to press until "Ad" appears 	

Use the icons   to move inside the menu.

Use the icon  to select menu items and to confirm changes made.

Pressing  and confirming the change will switch to the next item.

To exit from menu:



- continuously press the icon  for 10 sec.
- or wait 30 sec. for automatic shutdown

After 30 seconds from the last action, the control goes off and the settings is memorised.

Menu items			
Ad	Address	rb	Modbus reset
uu	(not applicable for this model)	Fr	Factory reset
Ub	Adjust buzzer volume	ot	Offset probe T
br	Adjust the brightness	oh	(not applicable for this model)
di	Digital input	Sc	Scale
rZ	(not applicable for this model)	rE	(not applicable for this model)



Set the modbus address of each individual unit controlled from one remote mounted control

To set the address:

Display	Operation
	<ul style="list-style-type: none"> the setting range is from a minimum of 01 to a maximum of 99 increase or decrease the number with the icons  

Adjust buzzer volume



To change the volume:

Display	Operation
	<ul style="list-style-type: none"> the volume setting range is from 00 (min) to 03 (max) increase or decrease the volume with the icons  





 The volume changes after you confirm the modification.

Adjust the brightness of the display

To adjust the brightness:

Display	Operation
	<ul style="list-style-type: none">• the brightness adjustment range is from 00 to 01• increase and decrease the brightness with the icons  

 The brightness changes after confirming the modification

 You can also reduce the brightness of the display through the control's key. From the display off, press the icon   for 20 sec. The message "01" will appear. Press  to decrease brightness "00". Wait 30 sec. for the correct settings to be verified.

Settings of the digital input

To change the digital input, select "di" menu:

Display	Operation
	<ul style="list-style-type: none">• CP / clean contact (default)• CO / cooling open• CC / cooling close

 By default, digital input is set to CP.

 By selecting CO, or CC the unit is locked in heating or cooling. This selection cannot be changed using  on the control.

 For return to the default settings, set the digital input to "CP".

Reset modbus (e.g. to change address of units)

Display	Operation
	<ul style="list-style-type: none">• select "no" to keep the current settings• select "YS" to reset the settings

Factory reset

To reset the control to factory settings:

Display	Operation
	<ul style="list-style-type: none">• select "YS" to reset the settings• select "no" to keep the current settings

Room temperature off-set calibration (on unit control)

Display	Operation
	<ul style="list-style-type: none">• the adjustment range is from -9 to 12

 Use this adjustment carefully.

 Use this adjustment only after having actually detected a discrepancy compared with the actual room temperature using a reliable device.

 Adjust the value in a range of -9 °C to +12 °C (16 °F - 54 °F), at variations of 0.1 °C/°F.

 After 30 seconds from the last action, the control goes off and the settings is memorised.

Scale

To change the temperature unit:

Display	Operation
	<ul style="list-style-type: none">• select °C or °F

0-10V Models

7.1 0-10V fan control

For units with 0-10V fan speed modulation, motor regulation can be made using an analogue 0-10V DC input with 25 kΩ impedance.

Valve actuators should be activated from the external control. If the remote 0-10V thermostat kit is used, a water temperature sensor is available as an accessory.

⚠ Take care to check impedance values, especially when controlling more than one unit in parallel.

7.2 Connection diagram with 0-10V DC thermostats / signals

Electrical connections for suitable thermostat:

L-N Electrical power supply 230V-50 Hz (115V/60Hz Canada/US)

M1 DC inverter fan motor

10V Appliance input 0-10 V

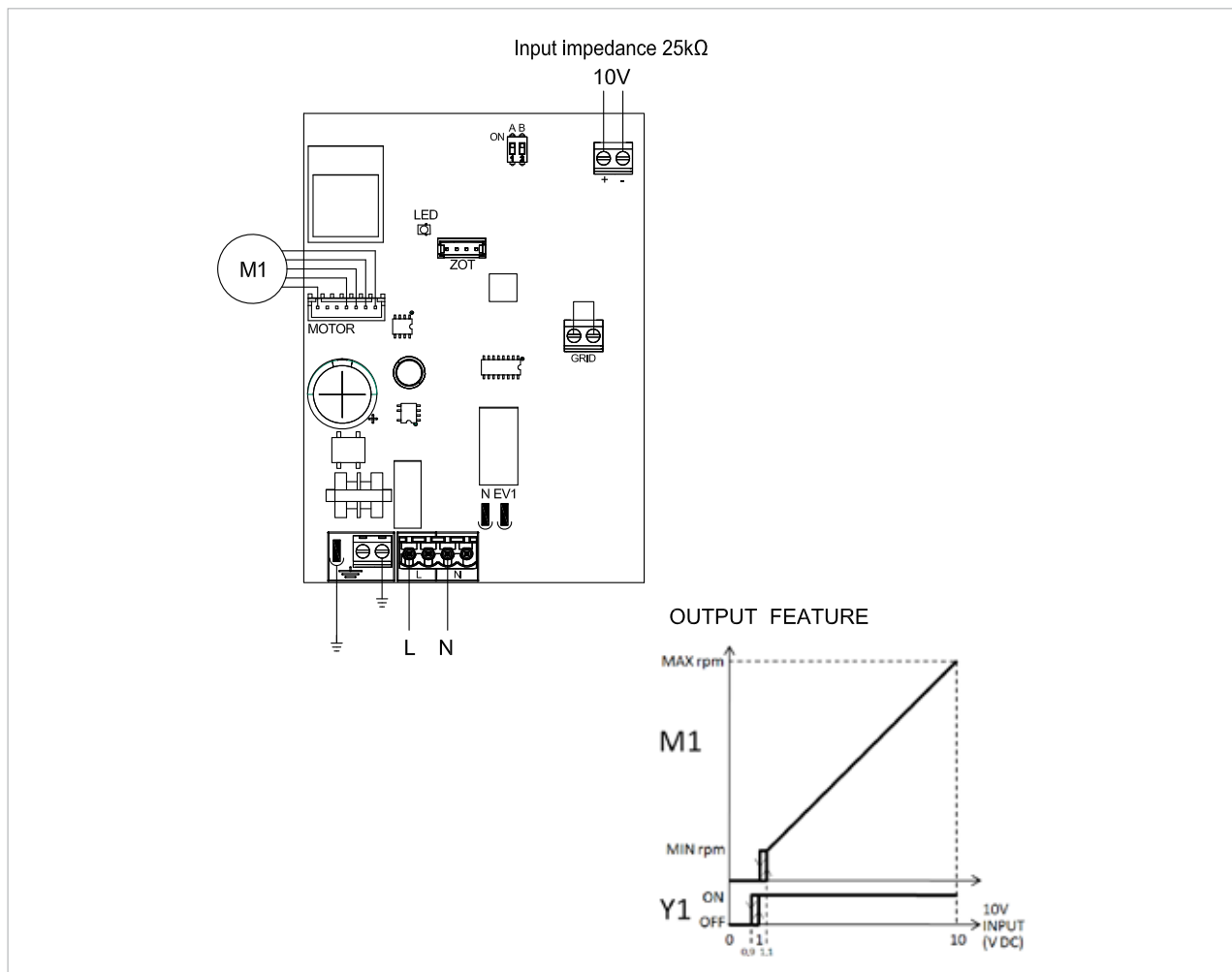

7.3 Fan speed regulation

The speed curve shows linear regulation from the minimum value (400 rpm) to the maximum value



(1,400 rpm) for voltage values $\geq 1.1V$ to 10 V DC. The motor is off when values are lower than 1V DC.

US User instructions

8.1 Onboard and remote-mounted control operation

These controls provide room temperature regulation in AUTO, SILENT, NIGHT and MAX programmes by using a temperature probe mounted in the lower part of the unit (onboard controls) or in the remote-mounted control.

The control panel has a memory, so settings will not be lost if the appliance is switched off or if the power supply is cut.

-  Anti-freeze protection is provided even in stand-by mode.
-  After 20 seconds from the last action, the panel brightness will be reduced, and the room temperature will appear on the display. Press any key to restore maximum brightness.
-  Faults on individual connected units will not be shown on the remote mounted control.









8.2 Display

Status and alarms are shown on the display by using the specific symbols below:

- | | |
|---|---|
|  Automatic |  Cooling mode |
|  Silent mode |  Flashing when presence switch CP closed |
|  Maximum fan speed |  Alarm indicator (solid light) |
|  Night-time mode |  Panel off indicator |
|  Heating mode |  (not applicable for this model) |

8.3 Key function



The various functions are set using 8 backlit keys

- | | |
|---|--|
|  Temp + is for increasing the set temperature |  Night-time mode: limits fan speed to a set level and the room temperature will fluctuate |
|  Temp - is for decreasing the set temperature |  Maximum fan speed: Allows for the maximum fan speed to be set |
|  Heating / Cooling: for changing between heating and cooling modes |  ON/Stand-By: for activating the device or for putting it in stand-by |
| AUTO Sets the fan speed automatically |  Silent: limits fan speed to a lower value |





8.4 Activation

Switch on the electrical power supply at the switched fused spur.

To activate the device

Key	Operation	Display
	Press the "ON" stand-by key	from off to on
AUTO 	Select one of the 4 operating modes by pressing the relative key.	

8.5 Heating/cooling mode settings

Key	Operation	Display
	Keep the Heating / Cooling key pressed for approx. 2 seconds to change the mode between heating and cooling, which is indicated by the 2 symbols that appear if heating or cooling is active.	
	When heating, the symbol displays when the set point is higher than ambient temperature, both are off when the set point is lower.	
	When cooling, the symbol displays when the set point is lower than ambient temperature, both are off when the set point is higher.	
	In the 4-pipe version, with automatic cooling/heating regulation system, when both symbols are displayed it signifies the set point has been reached (temperature is in the neutral band).	
	One of the two symbols flashing means that the water temperature (hot or cold) is not sufficient and stops the fan until the water temperature reaches a level needed to activate the fan.	If the water temperature is at the required level for heating or cooling after switching the power on, then start-up will occur the normal way with the fan working between the minimum and maximum limits.

8.6 Stand by

Key	Operation	Display
	Press and hold the ON Stand-By key for approx. 2 seconds. No illuminated signals on the display at all means that the system is in stand-by (no operation).	Off
	When the control is in stand-by mode, anti-freezing protection is guaranteed. If the ambient	temperature drops below 5°C (41 °F), the solenoid valves on the hot water output and the boiler are opened.



8.7 Temperature selection

Key	Operation	Display
	Set the required room temperature using the two increase/decrease keys to set the temperature value on the 3-digit display.	20.5
	The adjustment range is from 16 °C (61 °F) to 28°C (83 °F) in intervals of 0.5°C/°F, but out-of-range values are also accepted, from 5°C (41 °F) to 40°C (104 °F) (unless in auto mode). Only set these values for brief periods, and then set an intermediate value.	The controller is very precise - set it to the required value and wait for the controller to regulate itself according to the actual room temperature detected.



8.8 Automatic operation

Key	Operation	Display
AUTO	Press and hold the AUTO key. The function being activated is indicated by the relevant symbol appearing on the display.	A
Fan speed adjustment is carried out automatically between the minimum and maximum values,		according to the difference between room temperature and set temperature.



8.9 Silent operation

Key	Operation	Display
	Press and hold the Silent key. The function being activated is indicated by the relevant symbol appearing on the display.	
Fan speed is limited to a set maximum value.		

8.10 Night-time operation

Key	Operation	Display
	Press and hold the Night-time operation key. The function being activated is indicated by the relevant symbol appearing on the display.	
By selecting this mode, fan speed is limited to a set level and the set temperature is adjusted automatically, as follows:		<ul style="list-style-type: none"> • decreases by 1°C after one hour and by another degree after two hours in heating mode • increases by 1°C after one hour and by another degree after two hours in cooling mode

8.11 Operation at maximum fan speed

	Do not use for extended periods. Can cause motor damage.	
Key	Operation	Display
	Press and hold the Max Operation key. The function being activated is indicated by the relevant symbol appearing on the display.	
In this operation mode, the maximum possible power level is activated whether heating or cooling.		Once the desired room temperature is reached, we recommend selecting one of the other 3 operation modes for increased comfort and sound levels.

8.12 Key lock

Key	Operation	Display
	By pressing both the + and - keys for 3 seconds, all keys are locked locally, and this is indicated by "bL" appearing on the display. All actions are disabled to the user and whenever any key is pressed, "LOC" will appear. To unlock the keys, repeat the sequence.	bL

8.13 Reduce brightness to minimum

After 20 seconds from the last action, the panel brightness will be reduced for improved night-time comfort, and the room temperature will appear on		the display. If the brightness is still disturbing, the display can be switched off completely.
Key	Operation	Display
	With the display off, press and hold the + key for 5 seconds until "01" is displayed. Use the - key to change the value to 00 and wait 20 seconds to check the setting has been accepted.	00

8.14 Room temperature probe regulation offset

As the detection probe is towards the bottom of the device, the temperature detected may at times differ from the actual room temperature.

By using this function, the value displayed can be

Key	Operation
	With the display off, press and hold the - key for 5 seconds to access the menu which allows adjustment (using the + and - keys) of the AIR probe offset displayed, from -9 to +12 K (16 °F - 54 °F) in 0.1 K/°F intervals. After 20 seconds from the last action, the panel switches off and the setting is stored.

adjusted in a range from -9/+12 K (16 °F - 54 °F) in intervals of 0.1°C/°F.

Use this adjustment with care, and only after having confirmed a discrepancy compared with the actual room temperature using a reliable device.

Display



8.15 Switching off for longer periods

-  The antifreeze function is not active if the electrical supply to the unit is isolated. Care must be taken to prevent damage from freezing if the unit is switched off for a season or for holidays.



000000000001_Myson_MANUAL-Vector-S2_2022-07-01_01_US_NA_000000_01

MYSON is one of the oldest and most respected names in the heating industry. We have been manufacturing fan convectors for over 50 years. As one of the UK's leading brands, with a reputation for maximising the role of innovation and technology in our operations, we are committed to helping reduce national CO₂ emissions by developing energy efficient products that are capable of operating effectively at low flow temperatures.

Every care has been taken in the creation of this document. No part of this document may be reproduced without the express written consent of Purmo Group. Purmo Group accepts no responsibility for any inaccuracies or consequences arising from the use or misuse of the information contained herein.



Distributor: QHT Inc. | 3560 Lafayette Rd | Bldg 2, Unit A | Portsmouth | NH | 03801

Manufacturer: Purmo Group Ltd | Bulevardi 46 | P.O. Box 115 | FI-00121 Helsinki | Finland

Purmo Group and QHT Inc both reserve the right to make changes without notice due to continuing engineering and technological advances

www.purmoUSA.com
800-501-7697



PURMO
BY MYSON